

Carmel Standard Drawings

10-1	Typical Section – Primary Arterial	10-33	Standard Intersection
10-2	Typical Section – Primary Parkway	10-34	Median Island at Subdivision or Commercial Entrance
10-3	Typical Section – Urban Arterial	10-35	Auxiliary Lanes & Major Road Improvements
10-4	Typical Section – Arterial	10-36	Auxiliary Lanes for Left Turn Bay
10-5	Typical Section – Parkway Arterial	10-37A	Handrail
10-6	Typical Section – Urban Collector	10-37B	Handrail Base Plate Detail
10-7	Typical Section – Collector	10-38	Concrete Curb End Treatment Delineation
10-8	Typical Section – Parkway Collector	10-39	Fire Hydrant Marker Placement
10-9	Typical Section – Local Street	10-40	Service and Control Cabinet Detail
10-10A	Typical Section – Alley	10-41	Service and Control Cabinet Interior Detail
10-10B	Typical Section – Alley Pervious Pavement	10-42A	15' Light Pole Foundation Detail
10-11A	Street Signage Detail	10-42B	15' Light Pole and Luminaire
10-11B	Standard Blade Dimensional Detail	10-42C	Deco Wrap Base
10-11C	Street Name Signs	10-42D	Deco Wrap Base Detail
10-12	Underdrain	10-43A	30' Light Pole Foundation Detail
10-13	Concrete Roll Curb & Gutter	10-43B	30' Light Pole and Luminaire
10-14	Curb & Gutter Concrete Type II	10-43C	Deco Wrap Base
10-15	Curb & Gutter Concrete Type III	10-43D	Deco Wrap Base Detail
10-16	Straight Concrete Curb	10-44	Conduit/Innerduct Detail City of Carmel
10-17	Curb & Gutter B, Concrete, Modified	10-45	Conduit/Innerduct Detail Carmel Communications
10-18	Typical – Sidewalk Detail		
10-19	Sidewalk Adjacent To Curb		
10-20	Multi-Use Path		
10-21A	Residential Driveway – Depressed Curb		
10-21B	Residential Driveway – Concrete Roll Curb & Gutter		
10-22	Commercial Driveway – Depressed Curb		
10-23	Concrete Drive with Depressed Curb & Gutter		
10-24	Multi Use Path and Street Cut Repair Detail		
10-25A	Colored Concrete Pattern Detail		
10-25B	Roundabout Signage Detail		
10-25C	Roll Curb for Truck Apron		
10-25D	Barrier Curb at RAB Truck Apron Detail		
10-26	Subdivision Cul-de-sac A		
10-27	Subdivision Cul-de-sac B		
10-28	Install Curb Adjacent to Existing Pavement		
10-29A	Typical SSD Lateral to Individual Lots In Rear Yard		
10-29B	Typical SSD Lateral to Individual Lots Under Concrete Curb		
10-30	Typical Swale Details		
10-31	Trench Detail for City Storm Sewers		
10-32	Water & Sewer Main & Lateral Trench Detail for Utility Installations within The City R/W		

REVISED 4-05-17

CITY OF CARMEL STANDARDS

INDEX

RIGHT-OF-WAY
120'-0" PRIMARY ARTERIAL

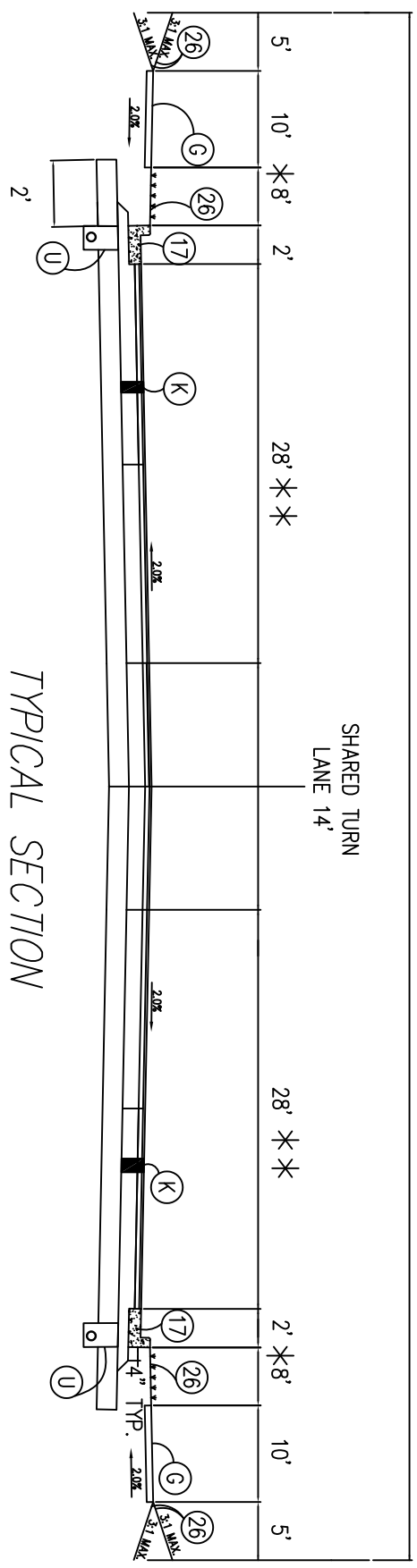

TYPICAL SECTION
PRIMARY ARTERIAL

NO SCALE

LEGEND

- HMA PAVEMENT**
- (K) 1.5" - 165#/SYD. HMA SURFACE, TYPE 'C', 9.5 mm ON
 - 2.5" - 275#/SYD. HMA INTERMEDIATE, TYPE 'C', 19.0 mm ON
 - 3.5" - 385#/SYD. HMA BASE, TYPE 'C', 25.0 mm ON
 - 2.5" - 250#/SYD. HMA INTERMEDIATE, TYPE 'C', 19.0 mm ON
 - 3" - 330#/SYD. HMA BASE, TYPE 'C', 25.0 mm ON
- INDOT, SUBGRADE TREATMENT, TYPE 1B OR 1C
- (U) UNDERDRAIN - SEE STANDARD DRAWING 10-12
 - (17) CURB TYPE II - SEE STANDARD DRAWING 10-14
 - (26) SODDING
 - (G) RECREATIONAL PATH
- 1.5" - 165#/SYD. HMA SURFACE, TYPE 'B' ON
2.5" - 275#/SYD. HMA INTERMEDIATE, TYPE 'B' ON
6" COMPACTED AGGREGATE, NO. 53 ON
COMPACTED SUBGRADE

- NOTES:
- * 6' MIN. TREE LAWN WHEN PRESENT
 - * GROSS SECTION DIMENSIONS ARE BASED ON CARMEL CLAY COMPREHENSIVE PLAN (C3PLAN)

STANDARD
DRAWING
10-1

CITY OF CARMEL STANDARDS
TYPICAL SECTION - PRIMARY ARTERIAL

RIGHT-OF-WAY
170'-0" PRIMARY PARKWAY

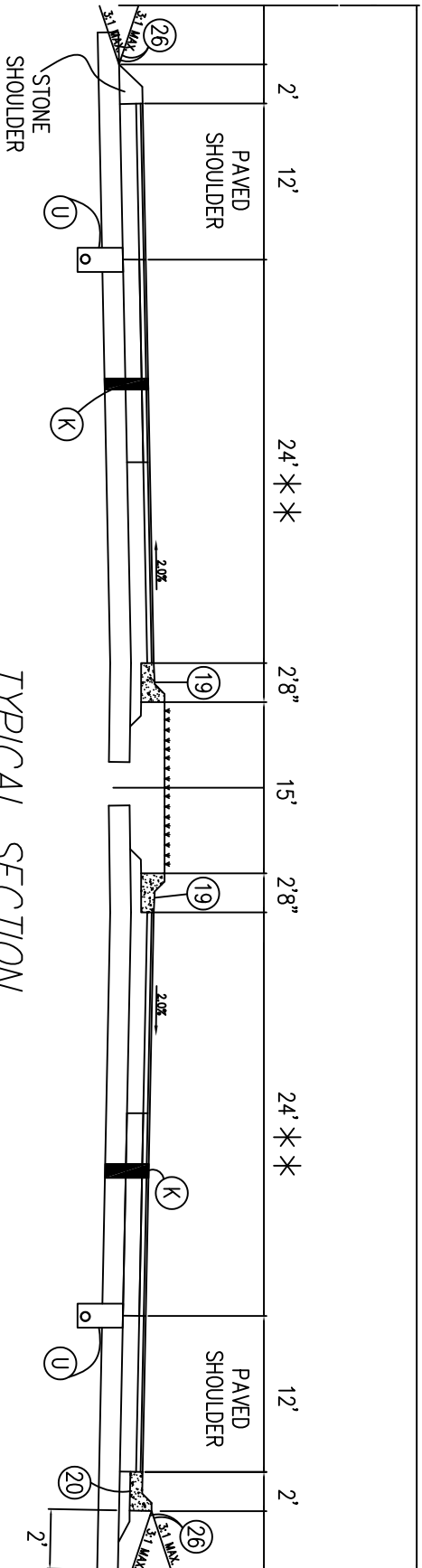

TYPICAL SECTION
PRIMARY PARKWAY

NO SCALE

LEGEND

HMA PAVEMENT

- (K) 1.5" - 165#/SYD. HMA SURFACE, TYPE 'C', 9.5 mm ON
- 2.5" - 275#/SYD. HMA INTERMEDIATE, TYPE 'C', 19.0 mm ON
- 3.5" - 385#/SYD. HMA BASE, TYPE 'C', 25.0 mm ON
- 2.5" - 250#/SYD. HMA INTERMEDIATE, TYPE 'C', OG 19.0 mm ON
- 3" - 330#/SYD. HMA BASE, TYPE 'C', 25.0 mm ON
- INDOT SUBGRADE TREATMENT, TYPE 1B OR 1C

- (U) UNDERDRAIN - SEE STANDARD DRAWING 10-12
- (19) CURB & GUTTER, B, CONCRETE, MODIFIED - SEE STANDARD DRAWING 10-17.
- (20) CURB & GUTTER, B, CONCRETE - SEE INDOT STANDARD DRAWING E605-CCC-01
- (26) SODDING

NOTES:

* * * * * CROSS SECTION DIMENSIONS ARE BASED ON
CARMEL CLAY COMPREHENSIVE PLAN (C3PLAN)

RIGHT-OF-WAY
98'-0" URBAN ARTERIAL

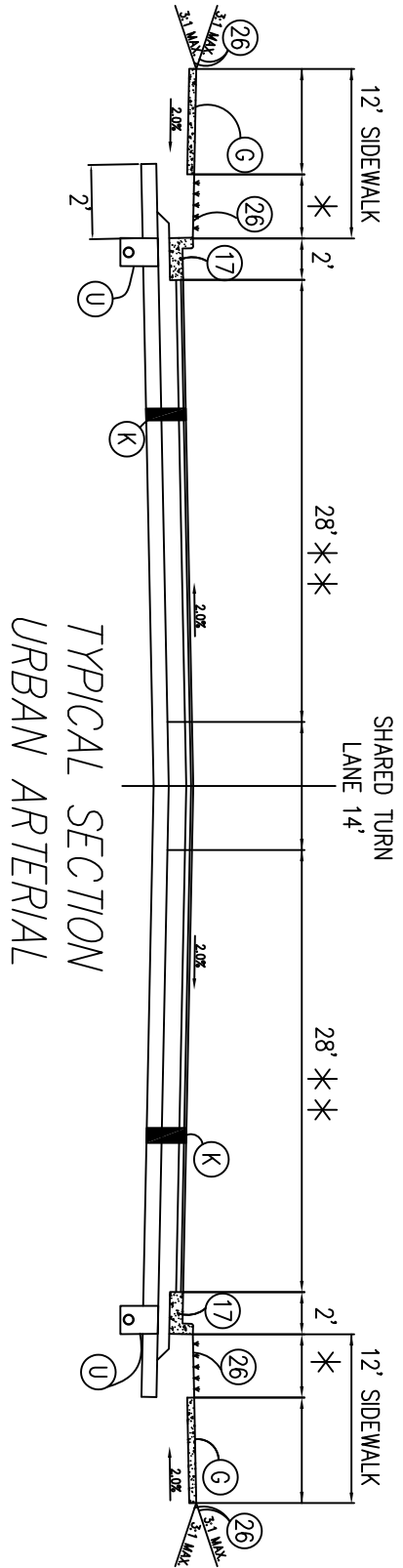

TYPICAL SECTION
URBAN ARTERIAL

NO SCALE

LEGEND

HMA PAVEMENT

- (K) 1.5" - 165#/SYD. HMA SURFACE, TYPE 'C', 9.5 mm ON
- 2.5" - 275#/SYD. HMA INTERMEDIATE, TYPE 'C', 19.0 mm ON
- 3.5" - 385#/SYD. HMA BASE, TYPE 'C', 25.0 mm ON
- 2.5" - 250#/SYD. HMA INTERMEDIATE, TYPE 'C', OG 19.0 mm ON
- 3" - 330#/SYD. HMA BASE, TYPE 'C', 25.0 mm ON
- INDOT SUBGRADE TREATMENT, TYPE 1B OR 1C
- (G) SIDEWALK - SEE STANDARD DRAWING 10-18
- (U) UNDERDRAIN - SEE STANDARD DRAWING 10-12
- (17) CURB TYPE II - SEE STANDARD DRAWING 10-14
- (26) SOODDING

- NOTES:
- * 6" MIN. TREE LAWN WHEN PRESENT
 - ** CROSS SECTION DIMENSIONS ARE BASED ON CARMEL CLAY COMPREHENSIVE PLAN (C3PLAN)

RIGHT-OF-WAY
100'-0" ARTERIAL

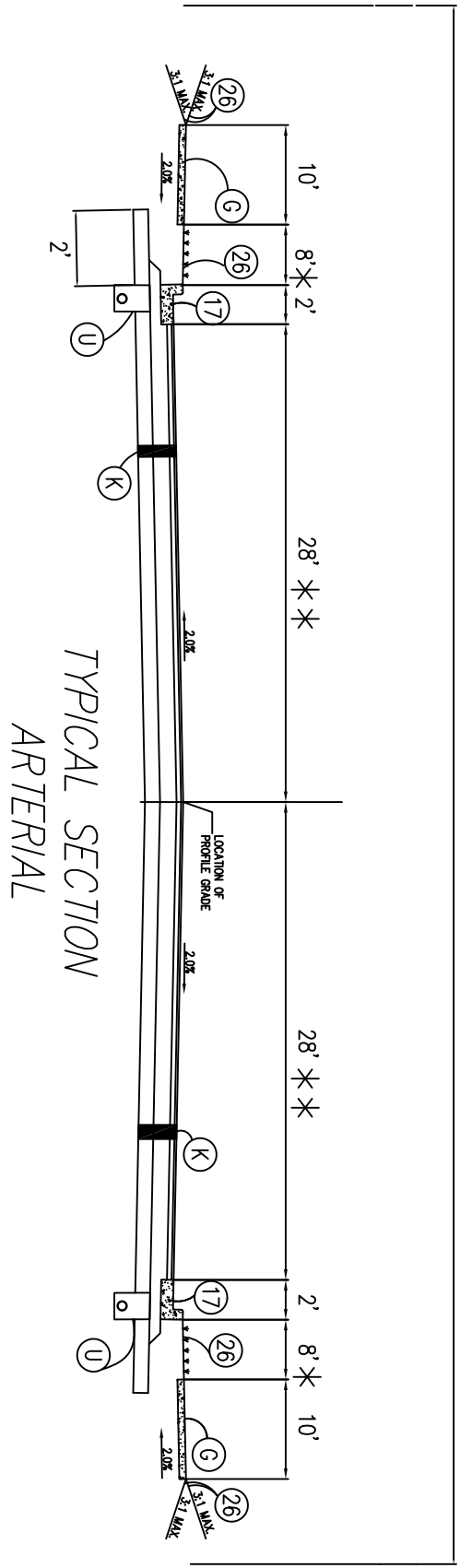

TYPICAL SECTION
ARTERIAL
NO SCALE

LEGEND

HMA PAVEMENT

- (K) 1.5" - 165#/SYD. HMA SURFACE, TYPE 'C', 9.5 mm ON
- 2.5" - 275#/SYD. HMA INTERMEDIATE, TYPE 'C', 19.0 mm ON
- 3.5" - 385#/SYD. HMA BASE, TYPE 'C', 25.0 mm ON
- 2.5" - 250#/SYD. HMA INTERMEDIATE, TYPE 'C' OG 19.0 mm ON
- 3" - 330#/SYD. HMA BASE, TYPE 'C', 25.0 mm ON
- INDOT SUBGRADE TREATMENT, TYPE 1B OR 1C
- (U) UNDERDRAIN - SEE STANDARD DRAWING 10-12
- (17) CURB TYPE II - SEE STANDARD DRAWING 10-14
- (26) SODDING
- (G) RECREATIONAL PATH
- 1.5" - 165#/SYD. HMA SURFACE, TYPE 'B' ON
- 2.5" - 275#/SYD. HMA INTERMEDIATE, TYPE 'B' ON
- 6" COMPACTED AGGREGATE, NO. 53 ON
- COMPACTED SUBGRADE

NOTES:

* 6' MIN. TREE LAWN WHEN PRESENT

* * * CROSS SECTION DIMENSIONS ARE BASED ON

CARMEL CLAY COMPREHENSIVE PLAN (C3PLAN)

STANDARD
DRAWING
10-4

CITY OF CARMEL STANDARDS
TYPICAL SECTION - ARTERIAL

RIGHT-OF-WAY
120'-0" PARKWAY ARTERIAL

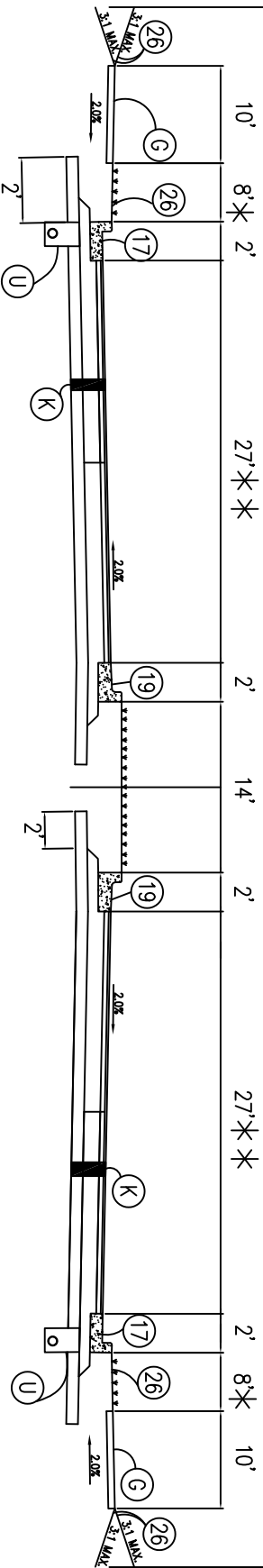

TYPICAL SECTION
PARKWAY ARTERIAL

LEGEND

NO SCALE

HMA PAVEMENT

- (K) 1.5" - 165#/SYD. HMA SURFACE, TYPE 'C', 9.5 mm ON
- 2.5" - 275#/SYD. HMA INTERMEDIATE, TYPE 'C', 19.0 mm ON
- 3.5" - 385#/SYD. HMA BASE, TYPE 'C', 25.0 mm ON
- 2.5" - 250#/SYD. HMA INTERMEDIATE, TYPE 'C', OG 19.0 mm ON
- 3" - 330#/SYD. HMA BASE, TYPE 'C', 25.0 mm ON
- INDOT SUBGRADE TREATMENT, TYPE 1B OR 1C
- (U) UNDERDRAIN - SEE STANDARD DRAWING 10-12
- (17) CURB TYPE II - SEE STANDARD DRAWING 10-14
- (19) CURB TYPE III - SEE STANDARD DRAWING 10-15
- (26) SODDING
- (G) RECREATIONAL PATH
- 1.5" - 165#/SYD. HMA SURFACE TYPE 'B' ON
- 2.5" - 275#/SYD. HMA INTERMEDIATE, TYPE 'B' ON
- 6" COMPACTED AGGREGATE, NO. 53 ON
- COMPACTED SUBGRADE

* NOTES:

* 6' MIN. TREE LAWN WHEN PRESENT

* * CROSS SECTION DIMENSIONS ARE BASED ON

CARMEL CLAY COMPREHENSIVE PLAN (C3PLAN)

RIGHT-OF-WAY
76'-0" URBAN COLLECTOR

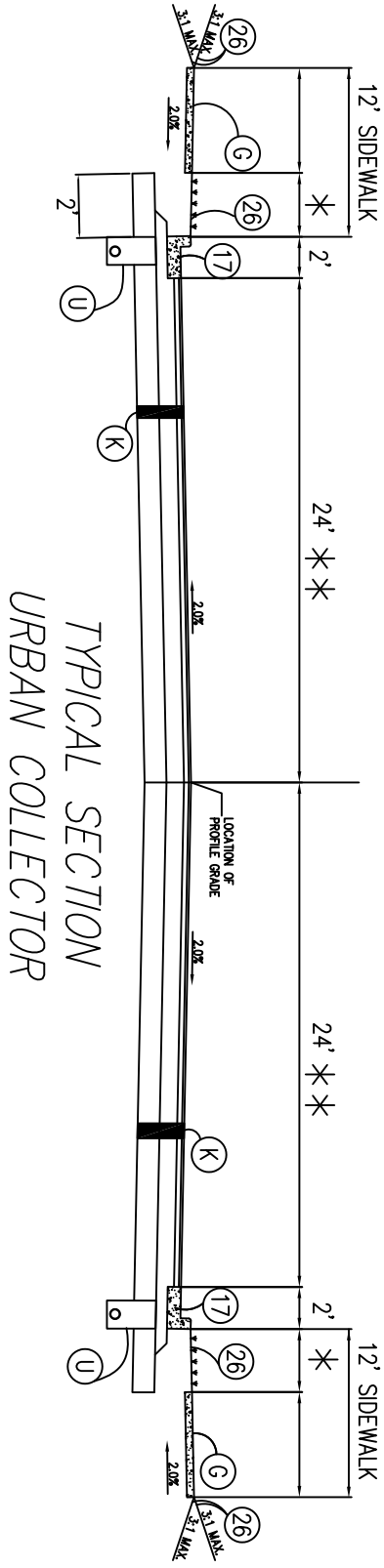

TYPICAL SECTION
URBAN COLLECTOR

NO SCALE

LEGEND

HMA PAVEMENT

- (K) 1.5" - 165#/SYD. HMA SURFACE, TYPE 'C', 9.5 mm ON
- 2.5 - 275#/SYD. HMA INTERMEDIATE, TYPE 'C', 19.0 mm ON
- 3.5' - 385#/SYD. HMA BASE, TYPE 'C', 25.0 mm ON
- 2.5" - 250#/SYD. HMA INTERMEDIATE, TYPE 'C', OG 19.0 mm ON
- 3" - 330#/SYD. HMA BASE, TYPE 'C', 25.0 mm ON
- INDOT SUBGRADE TREATMENT, TYPE 1B OR 1C
- (U) UNDERDRAIN - SEE STANDARD DRAWING 10-12
- (17) CURB TYPE II - SEE STANDARD DRAWING 10-14
- (26) SODDING
- (G) SIDEWALK - SEE STANDARD DRAWING 10-18

- NOTES:
- * 6' MIN. TREE LAWN WHEN PRESENT
 - * * * CROSS SECTION DIMENSIONS ARE BASED ON CARMEL CLAY COMPREHENSIVE PLAN (C3PLAN)

RIGHT-OF-WAY
90'-0" COLLECTOR STREET

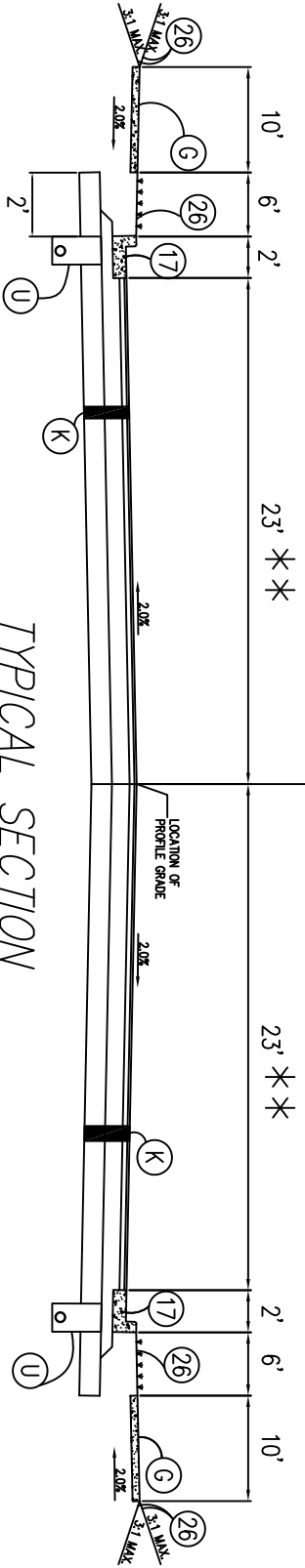

TYPICAL SECTION
COLLECTOR STREET

NO SCALE

LEGEND

HMA PAVEMENT

- (K) 1.5" - 165#/SYD. HMA SURFACE, TYPE 'C', 9.5 mm ON
- 2.5" - 275#/SYD. HMA INTERMEDIATE, TYPE 'C', 19.0 mm ON
- 3.5" - 385#/SYD. HMA BASE, TYPE 'C', 25.0 mm ON
- 2.5" - 250#/SYD. HMA INTERMEDIATE, TYPE 'C', 06 19.0 mm ON
- 3" - 330#/SYD. HMA BASE, TYPE 'C', 25.0 mm ON
- INDOT SUBGRADE TREATMENT, TYPE 1B OR 1C
- (U) UNDERDRAIN - SEE STANDARD DRAWING 10-12
- (17) CURB TYPE II - SEE STANDARD DRAWING 10-14 OR CONCRETE ROLL CURB & GUTTER - SEE STANDARD DRAWING 10-13
- (26) SODDING
- (G) RECREATIONAL PATH
1.5" - 165#/SYD. HMA SURFACE TYPE 'B' ON
2.5" - 275#/SYD. HMA INTERMEDIATE, TYPE 'B' ON
6" COMPACTED AGGREGATE, NO. 53 ON
COMPACTED SUBGRADE

NOTES:

- * * * * * CROSS SECTION DIMENSIONS ARE BASED ON CARMEL CLAY COMPREHENSIVE PLAN (C3PLAN)

STANDARD
DRAWING
10-7

CITY OF CARMEL STANDARDS
TYPICAL SECTION - COLLECTOR STREET

RIGHT-OF-WAY
90'-0" PARKWAY COLLECTOR

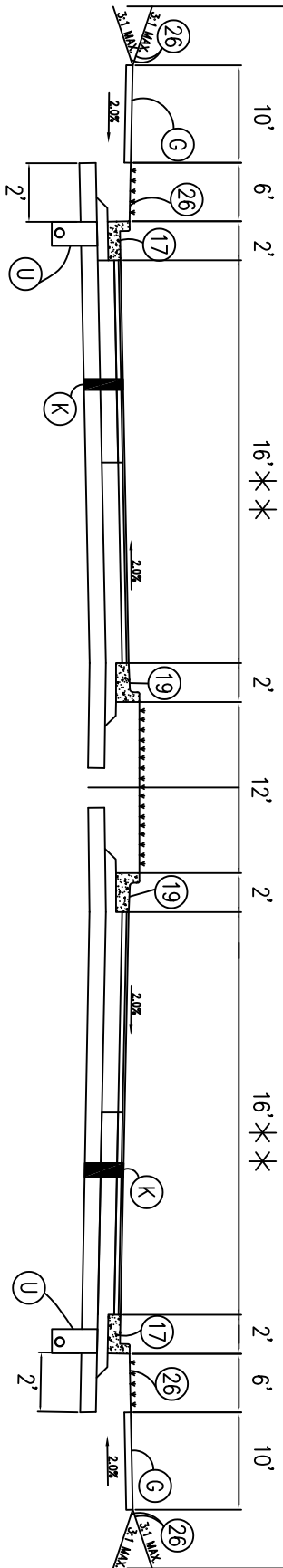

TYPICAL SECTION
PARKWAY COLLECTOR

NO SCALE

LEGEND

HMA PAVEMENT

- (K) 1.5" - 65#/SYD. HMA SURFACE, TYPE 'C', 9.5 mm ON
- 2.5" - 275#/SYD. HMA INTERMEDIATE, TYPE 'C', 19.0 mm ON
- 3.5" - 385#/SYD. HMA BASE, TYPE 'C', 25.0 mm ON
- 2.5" - 250#/SYD. HMA INTERMEDIATE, TYPE 'C', 06 19.0 mm ON
- 3" - 350#/SYD. HMA BASE, TYPE 'C', 25.0 mm ON
- INDOT SUBGRADE TREATMENT, TYPE 1B OR 1C
- (U) UNDERDRAIN - SEE STANDARD DRAWING 10-12
- (17) CURB TYPE II - SEE STANDARD DRAWING 10-14
- (19) CURB TYPE III - SEE STANDARD DRAWING 10-15
- (26) SODDING
- (G) RECREATIONAL PATH
- 1.5" - 165#/SYD. HMA SURFACE TYPE 'B' ON
- 2.5" - 275#/SYD. HMA INTERMEDIATE, TYPE 'B' ON
- 6" COMPACTED AGGREGATE, NO. 53 ON
- COMPACTED SUBGRADE

NOTES:

* 6' MIN. TREE LAWN WHEN PRESENT

* * * GROSS SECTION DIMENSIONS ARE BASED ON
CARMEL CLAY COMPREHENSIVE PLAN (C3PLAN)

STANDARD
DRAWING
10-8

CITY OF CARMEL STANDARDS

TYPICAL SECTION - PARKWAY COLLECTOR

RIGHT-OF-WAY
56'-0" LOCAL STREET

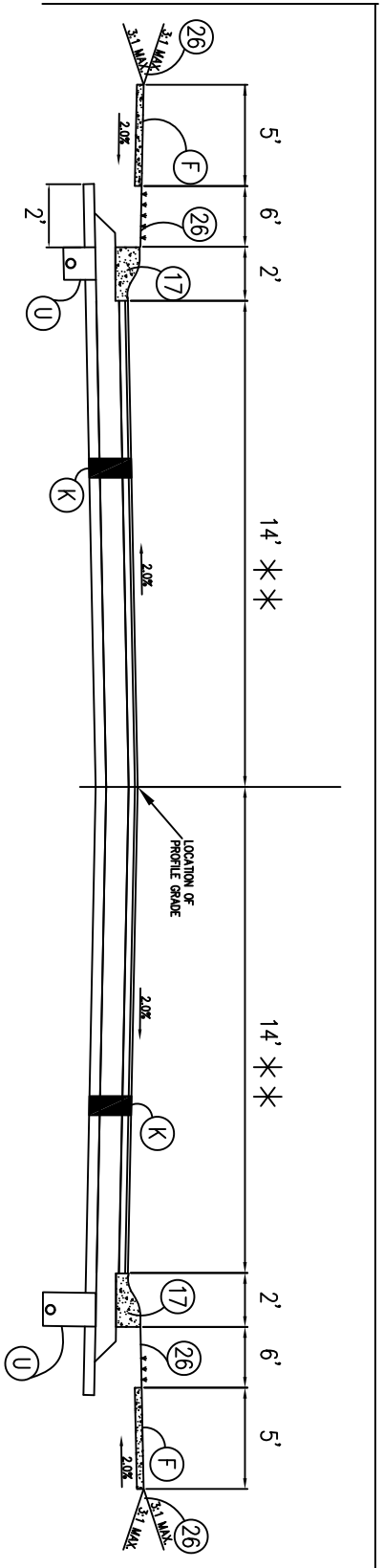

TYPICAL SECTION
LOCAL STREET

NO SCALE

LEGEND

HMA PAVEMENT

- (K) 1.5" - 165#/SYD. HMA SURFACE, TYPE 'B', 9.5 mm ON
- 2" - 220#/SYD. HMA INTERMEDIATE, TYPE 'B', 19.0 mm ON
- 3" - 330#/SYD. HMA BASE, TYPE 'B', 25.0 mm ON
- 6" COMPACTED AGGREGATE #53 ON
- INDOT SUBGRADE TREATMENT, TYPE 1B OR 1C
- (U) UNDERDRAIN - SEE STANDARD DRAWING 10-12
- (F) SIDEWALK - SEE STANDARD DRAWING 10-18
- (17) CONCRETE ROLL CURB AND GUTTER -
SEE STANDARD DRAWING 10-13
- (26) SODDING

NOTES:

- * * * CROSS SECTION DIMENSIONS ARE BASED ON
CARMEL CLAY COMPREHENSIVE PLAN (C3PLAN)

STANDARD
DRAWING
10-9

CITY OF CARMEL STANDARDS

TYPICAL SECTION - LOCAL STREET

RIGHT-OF-WAY
50'-0" ALLEY

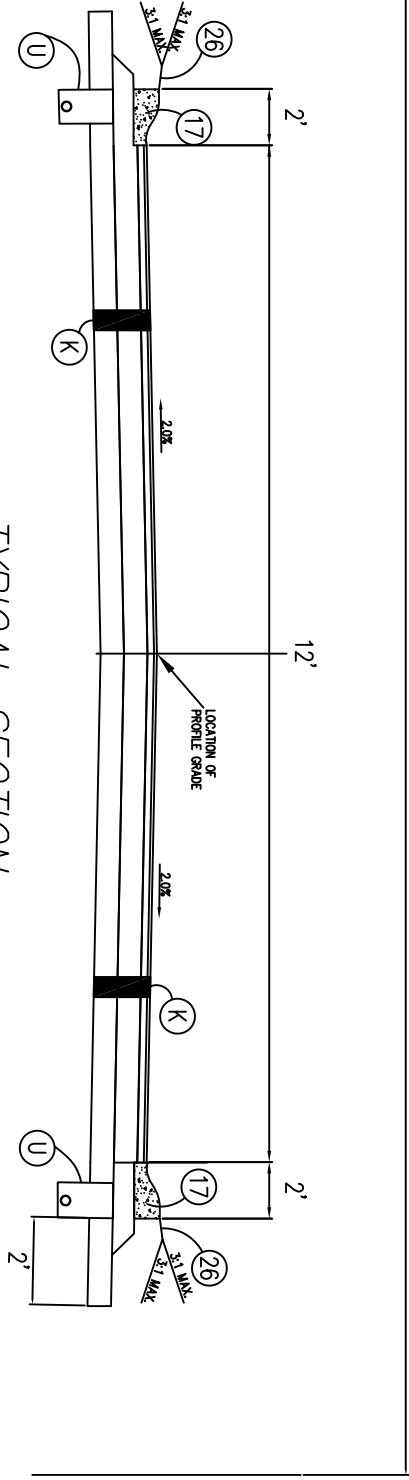

TYPICAL SECTION
ALLEY

LEGEND

HMA PAVEMENT

- (K) 1.5" - 165#/SYD. HMA SURFACE, TYPE 'B', 9.5 mm ON
- 2" - 220#/SYD. HMA INTERMEDIATE, 19.0 mm ON
- 3" - 330#/SYD. HMA BASE TYPE 'B', 25.0 mm ON
- 6" COMPACTED AGGREGATE #53 ON
- INDOT SUBGRADE TREATMENT, TYPE 1B OR 1C
- (U) UNDERDRAIN - SEE STANDARD DRAWING 10-12
- (17) CONCRETE ROLL CURB AND GUTTER -
SEE STANDARD DRAWING 10-13
- (26) SODDING

REVISED 3-22-17

STANDARD
DRAWING
10-10A

CITY OF CARMEL STANDARDS

TYPICAL SECTION - ALLEY

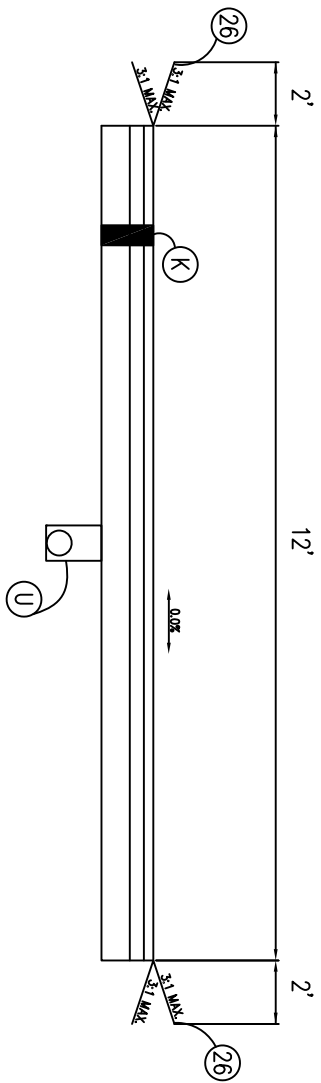

TYPICAL SECTION
ALLEY (PERVIOUS PAVEMENT)

NO SCALE

LEGEND

- (K)** PERVIOUS PAVEMENT
 6" PERVIOUS CONCRETE
 4" WASHED AGGREGATE #8
 12" AGGREGATE #2
 OR
 4" POROUS ASPHALT
 6" WASHED AGGREGATE #8
 12" AGGREGATE #2
- (26)** UNDERDRAIN – SEE STANDARD DRAWING 10-12
(26) SODDING

STANDARD
DRAWING
10-10B

CITY OF CARMEL STANDARDS

TYPICAL SECTION – ALLEY (PERVIOUS PAVEMENT)

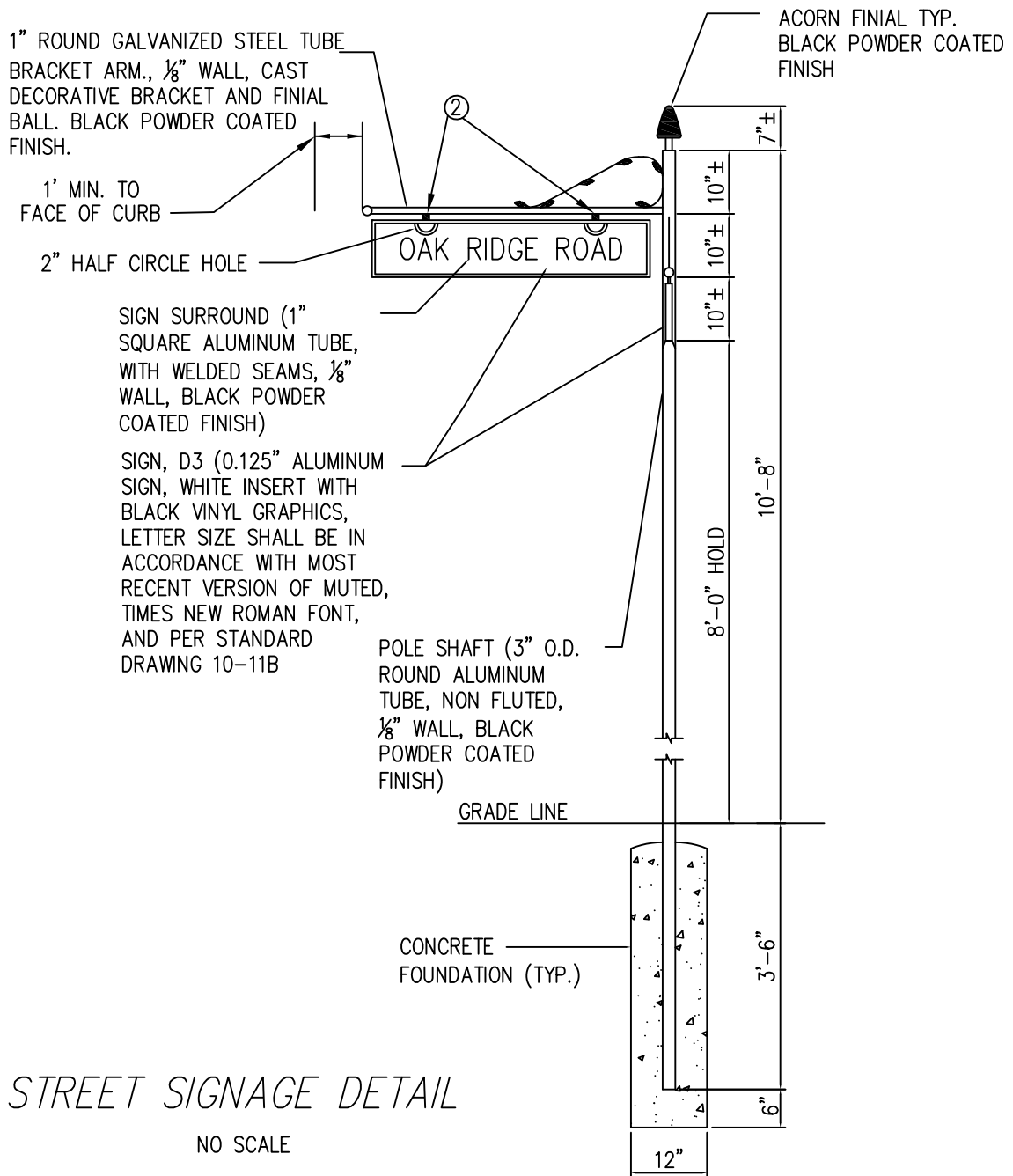

STREET SIGNAGE DETAIL

NO SCALE

NOTES:

1. FINISH TO BE BLACK POWDER COATED. ALL STREET NAME SIGNS TO BE PER GENERAL NOTES 2 & 3 ON STANDARD DRAWING 10-11B.
2. FASTENING SYSTEM SHALL BE STAINLESS STEEL EYE BOLT WITH LOCKNUT SUCH THAT THE SIGN CAN STAND HEAVY WINDS WITHOUT DAMAGE. THERE SHALL BE A MAXIMUM SEPARATION OF 2" BETWEEN THE TOP OF THE 1" TUBE SIGN SURROUND AND THE BOTTOM OF THE BRACKET ARM. ANY FASTENING OR MOUNTING HARDWARE PROVIDED SHALL BE CERTIFIED GRADE 8 STAINLESS STEEL.

STANDARD
DRAWING
10-11A

CITY OF CARMEL STANDARDS

STREET SIGNAGE DETAIL

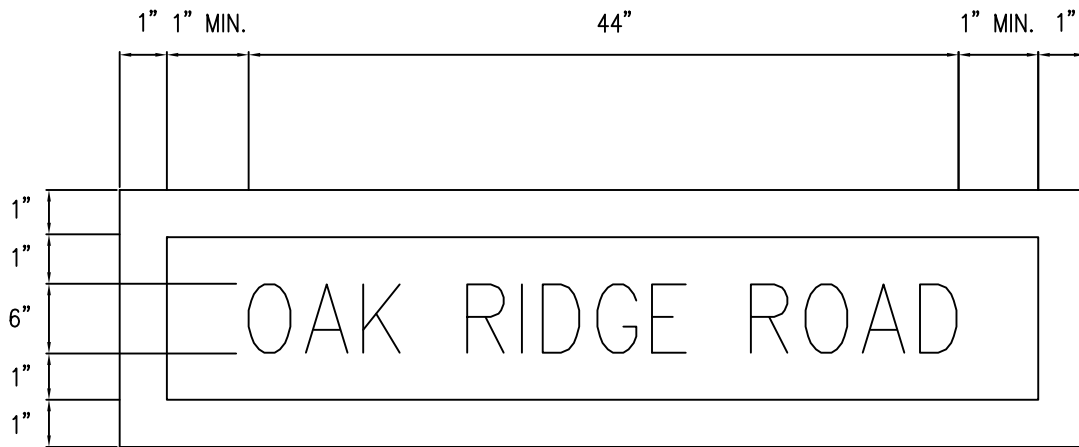

STANDARD BLADE DIMENSION

NO SCALE

ALL STANDARD CUSTOM BLADES HAVE A SPACE OF 44" FOR STREET NAMES. THEREFORE, LETTERING WIDTH SHALL BE ADJUSTED SO THAT STREET NAME FILLS THIS 44" SPACE AND SHOP DRAWINGS SHALL BE APPROVED BY THE CITY OF CARMEL. ALL LETTERS SHALL BE IN ACCORDANCE WITH MOST RECENT VERSION OF MUTCD. THE WORD INDICATING STREET, ROAD, PARKWAY, ETC. MAY BE ABBREVIATED OR SPELLED OUT DEPENDING ON THE STREET NAME, FOR EXAMPLE:

96TH STREET

FOR LESS LENGTHY STREET NAMES OR

MAIN STREET

WESTFIELD BLVD

FOR LENGTHY STREET NAMES

PENNSYLVANIA ST

GENERAL NOTES:

- IF CUSTOM SIGNAGE IS NECESSARY AND THE STANDARD BLADES CANNOT ACCOMMODATE THE INFORMATION, LARGER BLADES CAN BE SUBMITTED FOR APPROVAL. ANY CUSTOM BLADES OVER 48" IN LENGTH SHALL BE PLACED ON TWO CUSTOM POSTS.
- ALL STREET ID SIGNS AT STANDARD INTERSECTIONS SHALL BE TWO SIDED UNLESS DIRECTED OTHERWISE.
- ALL STREET ID SIGNS AT ROUNDABOUT INTERSECTIONS OR THAT ARE FOR ONE DIRECTION OF TRAVEL SHALL BE ONE SIDED UNLESS DIRECTED OTHERWISE. THERE SHALL ALSO BE A DIRECTIONAL ARROW PLACED AT THE END OF THE STREET NAME INDICATING THE DIRECTION OF TRAVEL FOR WHICH THE STREET SIGN DESIGNATES. PLEASE REFER TO STANDARD DRAWING 10-25B FOR TYP. ROUNDABOUT SIGN PLACEMENT: NOTE 5.

STANDARD
DRAWING
10-11B

CITY OF CARMEL STANDARDS

STANDARD BLADE DIMENSION DETAIL

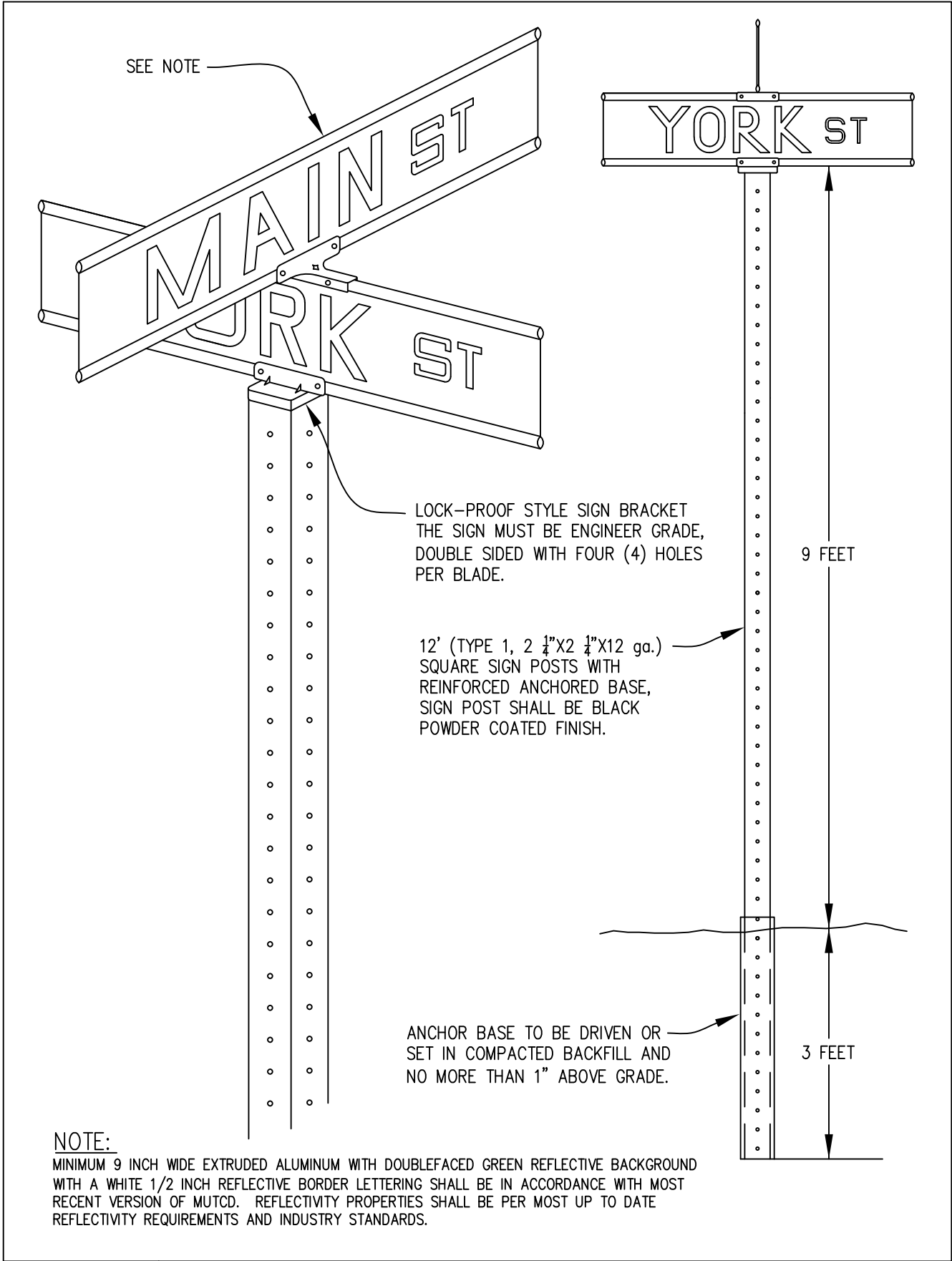

STANDARD
DRAWING
10-11C

CITY OF CARMEL STANDARDS

STREET NAME SIGNS

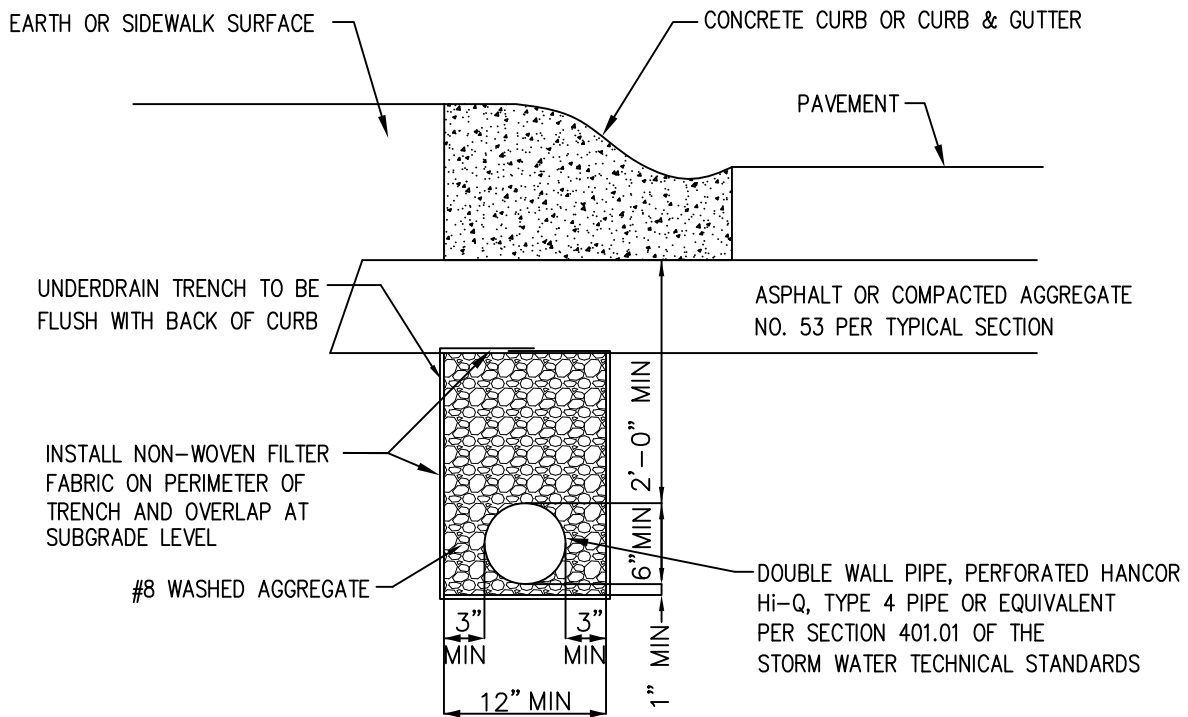

UNDERDRAIN
NO SCALE

NOTES:

PIPE SHALL CONFORM TO SPEC REQUIREMENTS OF SECTION 718 OF STANDARD SPECIFICATION

INSTALLATION REQUIRED: BOTH SIDES OF PAVEMENT AND WHERE REQUESTED BY THE CITY ENGINEER

STANDARD
DRAWING
10-12

CITY OF CARMEL STANDARDS

UNDERDRAIN

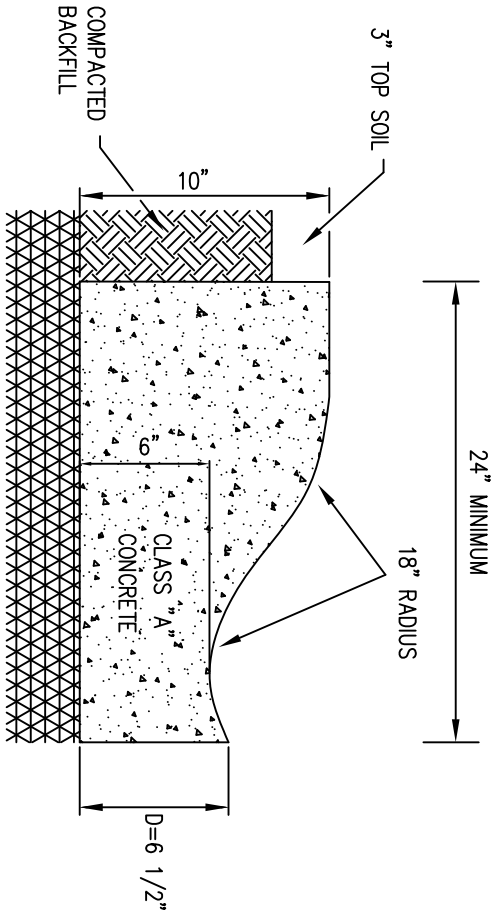

CONCRETE ROLL CURB & GUTTER

NO SCALE

- NOTES: INTEGRAL CURB WITH CONCRETE PAVEMENT SHALL BE SIMILAR SHAPE
 CURE ALL EXPOSED SURFACES
 CONTRACTION JOINTS SHALL BE SAWED IN CONTINUOUSLY POURED CURBS TO A MINIMUM DEPTH OF 1/3" D
 DAMPEN SUBGRADE BEFORE PLACING CONCRETE
 CONTROL JOINTS EVERY 5' MAXIMUM ON RADII OTHERWISE EVERY 10' MAXIMUM. PREFORMED EXPANSION JOINT EVERY 50' MAXIMUM.
 NO BACKFILLING OR COMPACTION MAY OCCUR 12' FROM CURB UNTIL 5 FULL DAYS HAVE PASSED AFTER PLACING CONCRETE
 SHALL BE INSTALLED IN ACCORDANCE WITH INDOT STANDARD SPECIFICATIONS.

STANDARD
 DRAWING
 10-13

CITY OF CARMEL STANDARDS

CONCRETE ROLL CURB & GUTTER

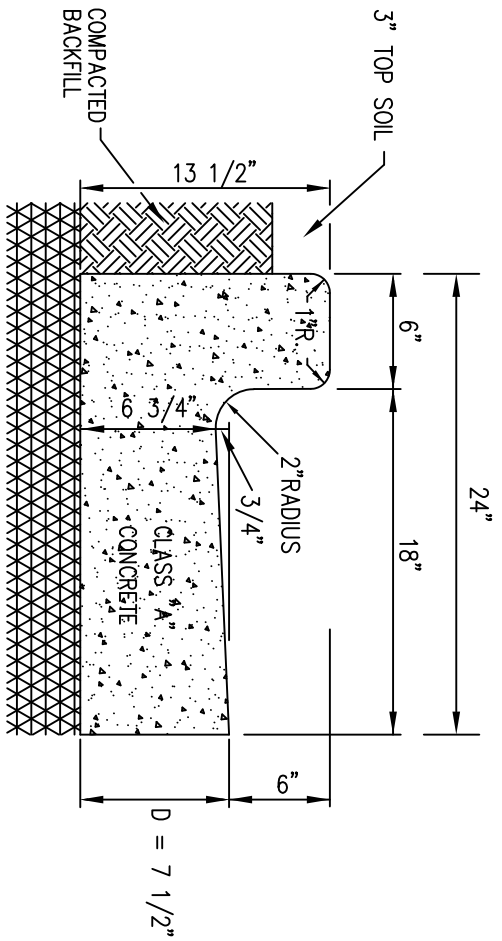

CURB AND GUTTER, CONCRETE, TYPE II

NO SCALE

NOTES: INTEGRAL CURB WITH CONCRETE PAVEMENT SHALL BE SIMILAR SHAPE
 CURE ALL EXPOSED SURFACES
 CONTRACTION JOINTS SHALL BE SAWED IN CONTINUOUSLY Poured CURBS TO A MINIMUM DEPTH OF 1/3" D
 DAMPEN SUBGRADE BEFORE PLACING CONCRETE
 CONTROL JOINTS EVERY 5' MAXIMUM ON RADI OTHERWISE EVERY 10' MAXIMUM. PREFORMED EXPANSION JOINT EVERY 50' MAXIMUM.
 NO BACKFILLING OR COMPACTION MAY OCCUR 12' FROM CURB UNTIL 5 FULL DAYS HAVE PASSED AFTER PLACING CONCRETE
 SHALL BE INSTALLED IN ACCORDANCE WITH INDOT STANDARD SPECIFICATIONS.

STANDARD
 DRAWING
 10-14

CITY OF CARMEL STANDARDS
 CURB AND GUTTER, CONCRETE, TYPE II

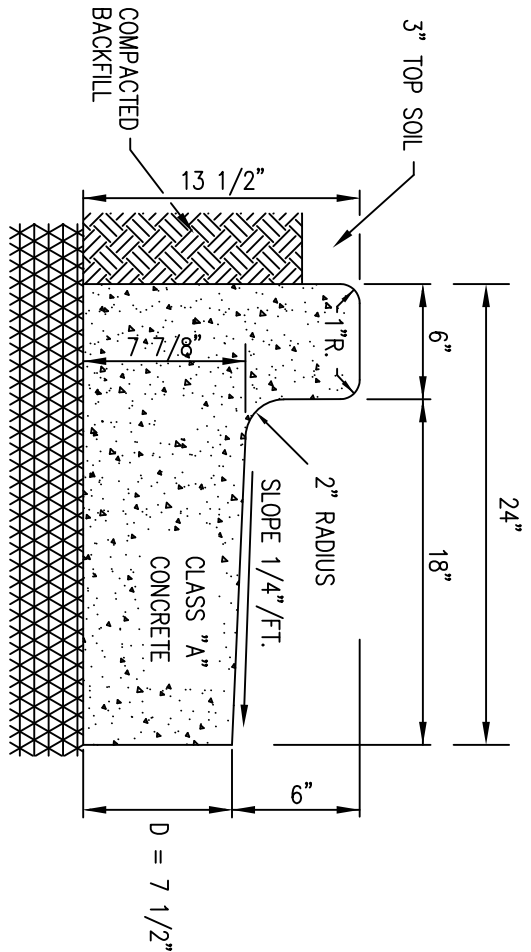

CURB AND GUTTER, CONCRETE, TYPE III

NO SCALE

- NOTES: INTEGRAL CURB WITH CONCRETE PAVEMENT SHALL BE SIMILAR SHAPE
- CURE ALL EXPOSED SURFACES
- CONTRACTION JOINTS SHALL BE SAWED IN CONTINUOUSLY POURED CURBS TO A MINIMUM DEPTH OF 1/3" D
- DAMPEN SUBGRADE BEFORE PLACING CONCRETE
- CONTROL JOINTS EVERY 5' MAXIMUM ON RADI OTHERWISE EVERY 10' MAXIMUM. PERFORMED EXPANSION JOINT EVERY 50' MAXIMUM.
- NO BACKFILLING OR COMPACTION MAY OCCUR 12' FROM CURB UNTIL 5 FULL DAYS HAVE PASSED AFTER PLACING CONCRETE
- SHALL BE INSTALLED IN ACCORDANCE WITH INDOT STANDARD SPECIFICATIONS.

STANDARD
DRAWING
10-15

CITY OF CARMEL STANDARDS
CURB AND GUTTER, CONCRETE, TYPE III

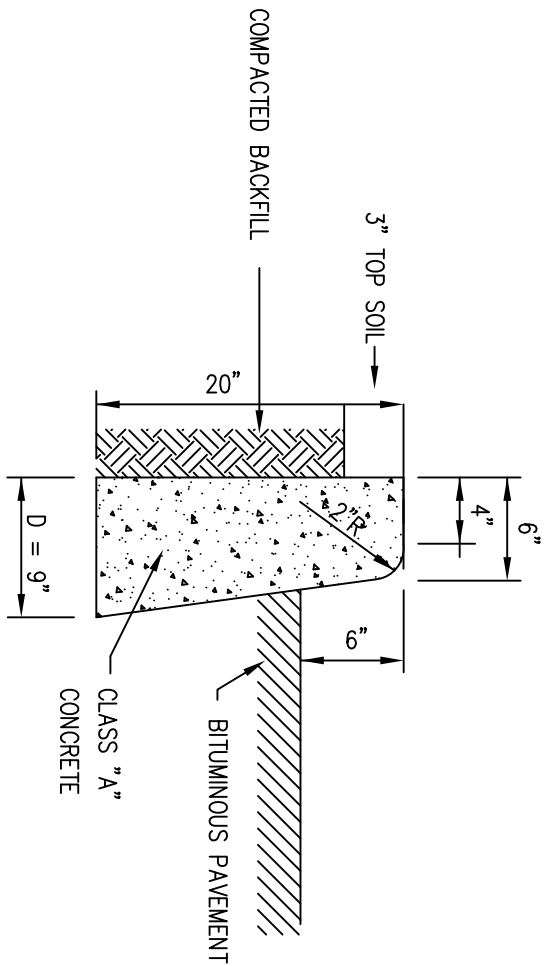

STRAIGHT CONCRETE CURB

NO SCALE

- NOTES: INTEGRAL CURB WITH CONCRETE PAVEMENT SHALL BE SIMILAR SHAPE
- CURE ALL EXPOSED SURFACES
- CONTRACTION JOINTS SHALL BE SAWED IN CONTINUOUSLY Poured CURBS TO A MINIMUM DEPTH OF 1/3" D
- DAMPEN SUBGRADE BEFORE PLACING CONCRETE
- CONTROL JOINTS EVERY 5' MINIMUM ON RADI OTHERWISE EVERY 10' MINIMUM
- NO BACKFILLING OR COMPACTION MAY OCCUR 12' FROM CURB UNTIL 5 FULL DAYS HAVE PASSED AFTER PLACING CONCRETE
- SHALL BE IN ACCORDANCE WITH INDOT STANDARD SPECIFICATIONS.

STANDARD DRAWING 10-16	<i>CITY OF CARMEL STANDARDS</i>
	STRAIGHT CONCRETE CURB

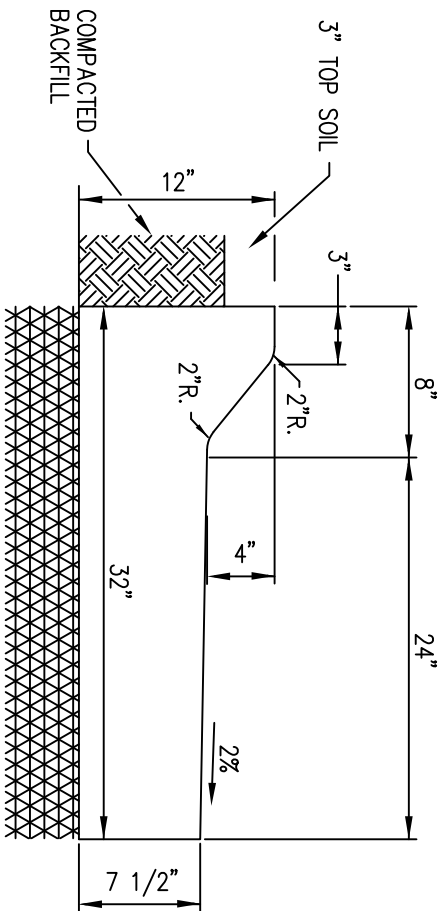

CURB AND GUTTER, B, CONCRETE, MODIFIED

NO SCALE

NOTES: INTEGRAL CURB WITH CONCRETE PAVEMENT SHALL BE SIMILAR SHAPE
CURE ALL EXPOSED SURFACES

CONTRACTION JOINTS SHALL BE SAWED IN CONTINUOUSLY POURED CURBS TO A MINIMUM DEPTH OF 1/3" D
DAMPEN SUBGRADE BEFORE PLACING CONCRETE

CONTROL JOINTS EVERY 5' MINIMUM ON RADII OTHERWISE EVERY 10' MINIMUM
NO BACKFILLING OR COMPACTION MAY OCCUR 12' FROM CURB UNTIL 5 FULL DAYS HAVE PASSED AFTER PLACING CONCRETE
SHALL BE IN ACCORDANCE WITH INDOT STANDARD SPECIFICATIONS.

STANDARD
DRAWING
10-17

CITY OF CARMEL STANDARDS

CURB AND GUTTER, B, CONCRETE, MODIFIED

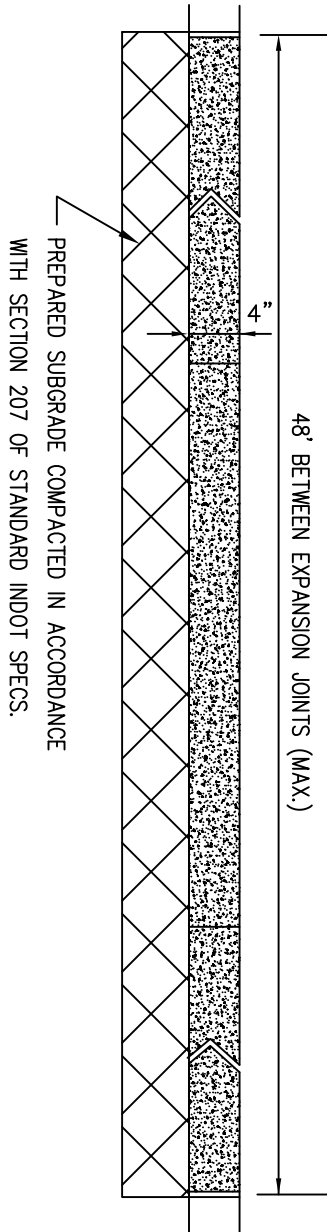
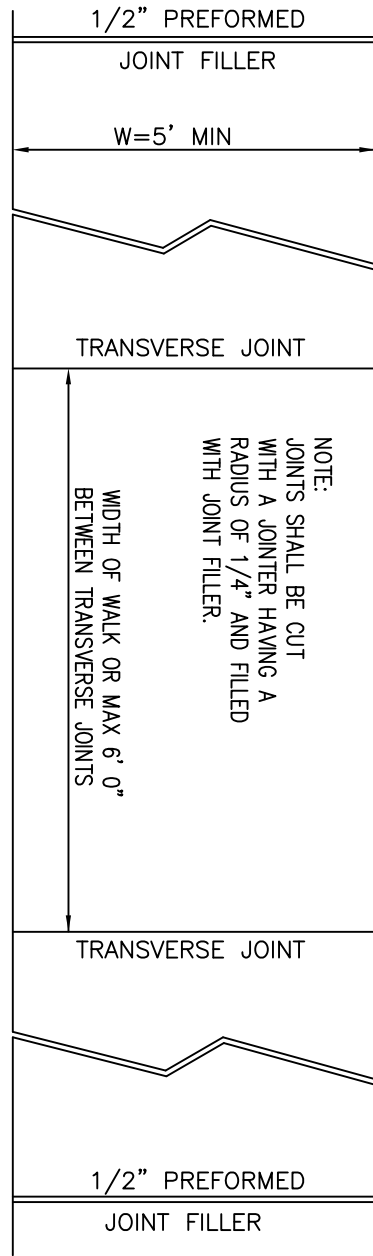

CONCRETE SIDEWALK

NO SCALE

NOTES:

EGGED AND BROOM FINISHED . NO "PICTURE FRAME" FINISHES WILL BE PERMITTED

CLASS 'A' CONCRETE

6" DEPTH OF CONCRETE AND 6" COMPACTED AGGREGATE NO. 53 TO BE USED ACROSS DRIVES

IF AGGREGATE IS REQUIRED #53 STONE WILL BE USED AT A MINIMUM OF 4", WITH EXCEPTION OF ACROSS DRIVES

STANDARD
DRAWING
10-18

CITY OF CARMEL STANDARDS
TYPICAL - SIDEWALK DETAIL

6" MIN PER INDOT STANDARD DRAWING E604-SDWK-02

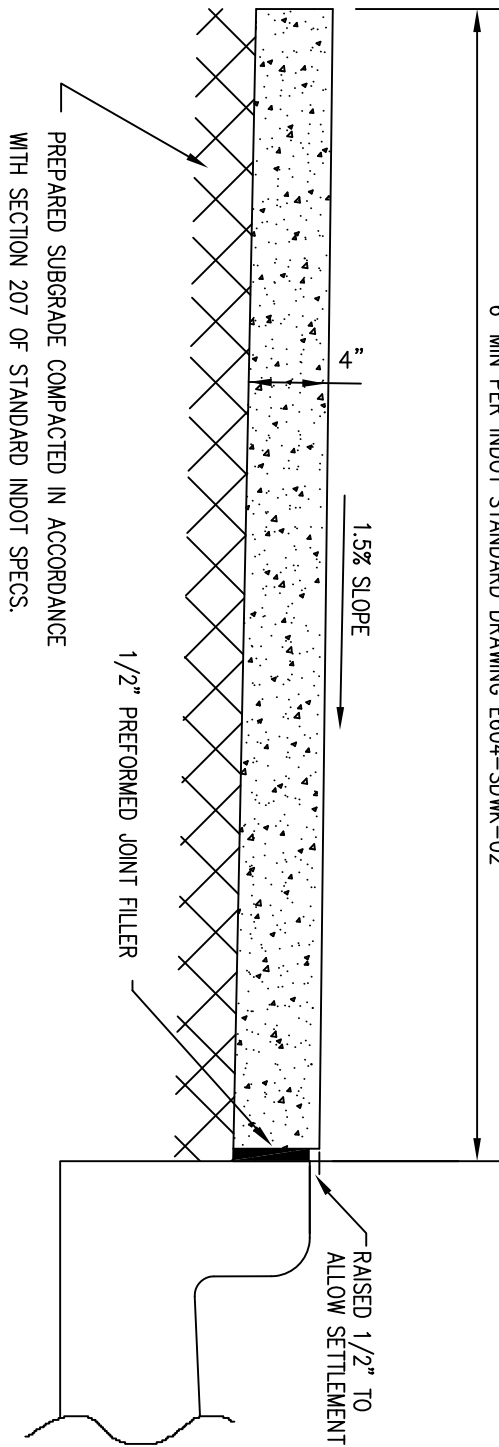

SIDEWALK ADJACENT TO CURB

NO SCALE

NOTES: EDGE AND BROOM FINISH. NO "PICTURE FRAME" FINISHES WILL BE PERMITTED
CLASS 'A' CONCRETE

6" DEPTH OF CONCRETE AND 6" COMPACTED AGGREGATE, NO 53 TO BE USED ACROSS DRIVES
IF AGGREGATE IS REQUIRED #53 STONE WILL BE USED AT A MINIMUM OF 4", WITH EXCEPTION OF ACROSS DRIVES

STANDARD
DRAWING
10-19

CITY OF CARMEL STANDARDS

SIDEWALK ADJACENT TO CURB

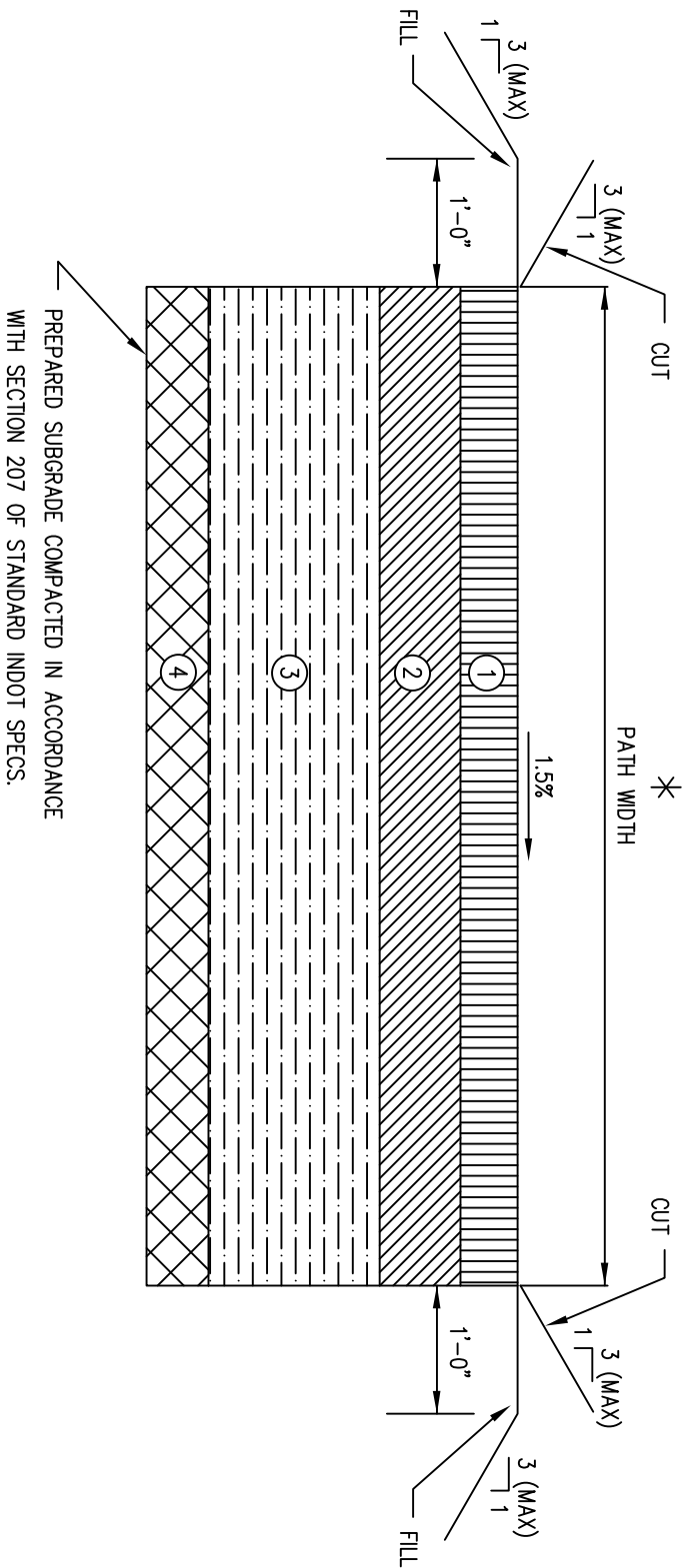

PREPARED SUBGRADE COMPACTED IN ACCORDANCE WITH SECTION 207 OF STANDARD INDOT SPECS.

MULTI-USE PATH

NO SCALE

- ① 1.5" - 165#/SYD. HMA SURFACE, TYPE 'B', 9.5 mm ON
 - ② 2.5" - 275#/SYD. HMA INTERMEDIATE, TYPE 'B', 19.0 mm ON
 - ③ 6" COMPACTED AGGREGATE #53 ON
 - ④ COMPACTED SUBGRADE
- * WIDTH OF RECREATIONAL ASPHALT PATH AS DESIGNATED BY CARMEL CLAY COMPREHENSIVE PLAN (C3 PLAN)

STANDARD DRAWING 10-20	<i>CITY OF CARMEL STANDARDS</i>
	MULTI-USE PATH

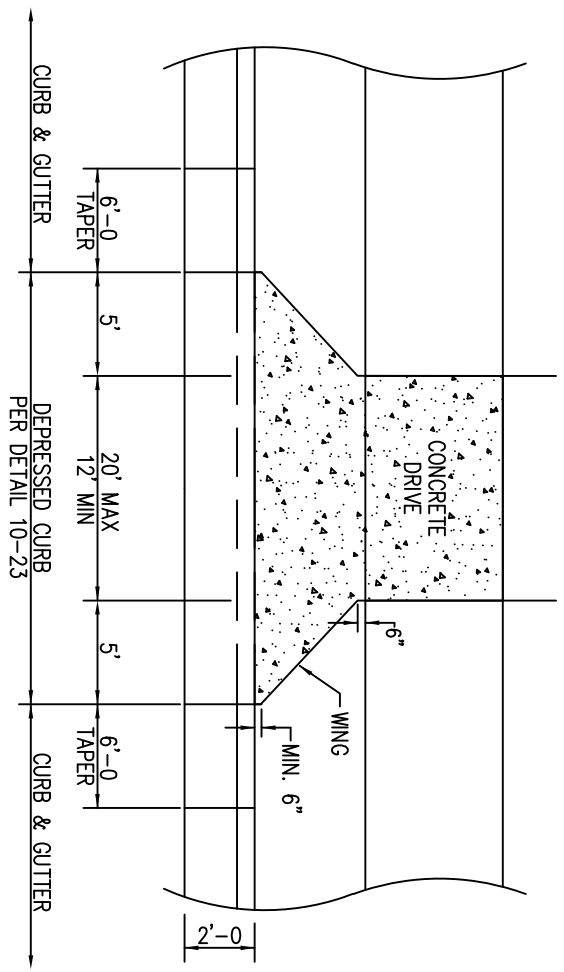
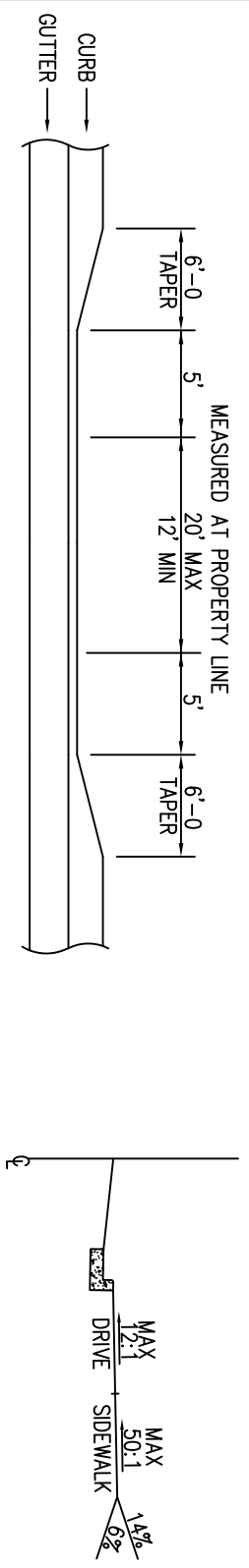

FOR ALL APPLICATIONS EXCEPT ROLL CURB
RESIDENTIAL DRIVEWAYS
 NO SCALE

NOTES:

- ALL ROADS FACE OF CURB IS TO BE 7 1/2", BACK OF CURB 13 1/2"
- ANY EXISTING CURB, SHALL BE SAWCUT AT THE NEAREST JOINT TO THE REMOVAL LIMITS AND THE EXISTING CURB REMOVED.
- CONCRETE DRIVE AND/OR SIDEWALK ACROSS DRIVE SHALL BE A MINIMUM OF 6" PLAIN CONCRETE AND 6" COMPACTED AGGREGATE NO 53.
- WINGS SHALL BE SIZED AS NOTED REGARDLESS OF EXISTENCE OR LOCATION OF SIDEWALK
- PATH/SIDEWALK AND TREE LAWN DIMENSIONS VARY PER CARMEL CLAY COMPREHENSIVE PLAN (C3 PLAN).

STANDARD
DRAWING
10-21A

CITY OF CARMEL STANDARDS
 RESIDENTIAL DRIVEWAY – DEPRESSED CURB

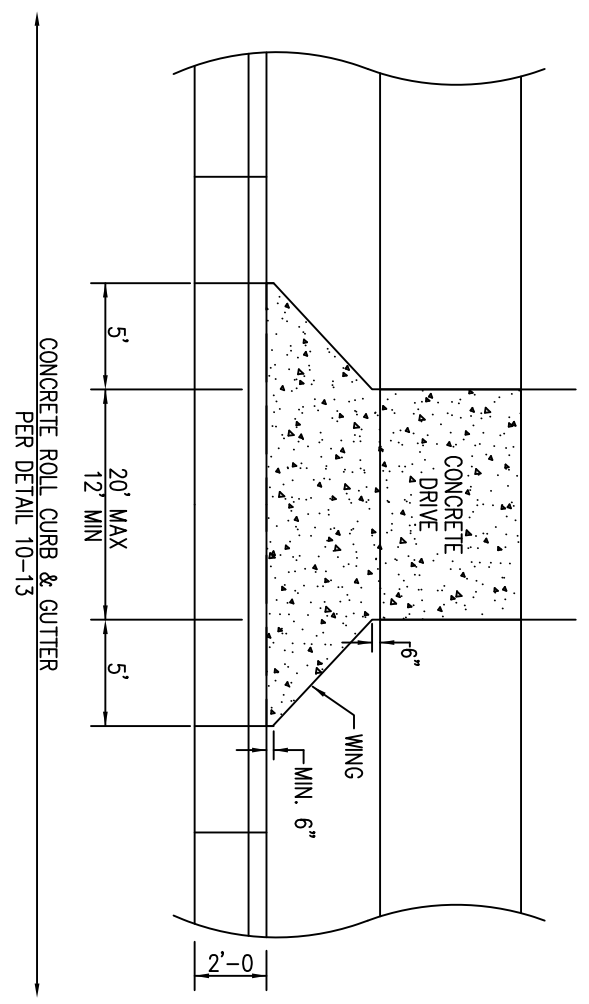
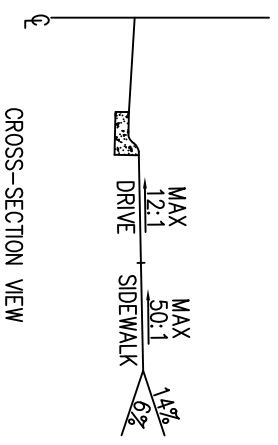
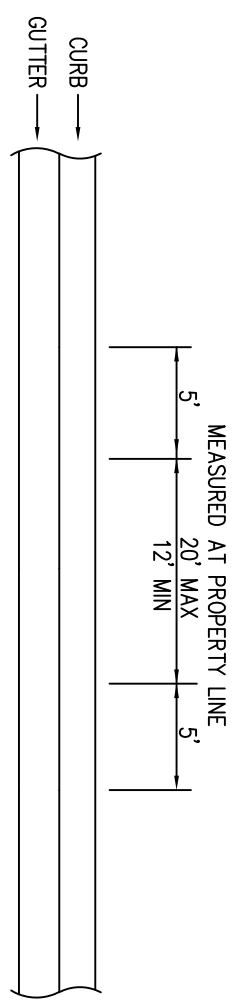

RESIDENTIAL DRIVEWAYS

NO SCALE

NOTES:

- FOR LOCAL ROADS FACE OF CURB IS TO BE 6 1/2", BACK OF CURB 10".
- ANY EXISTING CURB, SHALL BE SAWCUT AT THE NEAREST JOINT TO THE REMOVAL LIMITS AND THE EXISTING CURB REMOVED.
- CONCRETE DRIVE AND/OR SIDEWALK ACROSS DRIVE SHALL BE A MINIMUM OF 6" PLAIN CONCRETE AND 6" COMPACTED AGGREGATE NO 53.
- WINGS SHALL BE SIZED AS NOTED REGARDLESS OF EXISTENCE OR LOCATION OF SIDEWALK
- PATH/SIDEWALK AND TREE LAWN DIMENSIONS VARY PER CARMEL CLAY COMPREHENSIVE PLAN (C3 PLAN).

STANDARD
DRAWING
10-21B

CITY OF CARMEL STANDARDS

RESIDENTIAL DRIVEWAY CONCRETE ROLL CURB & GUTTER

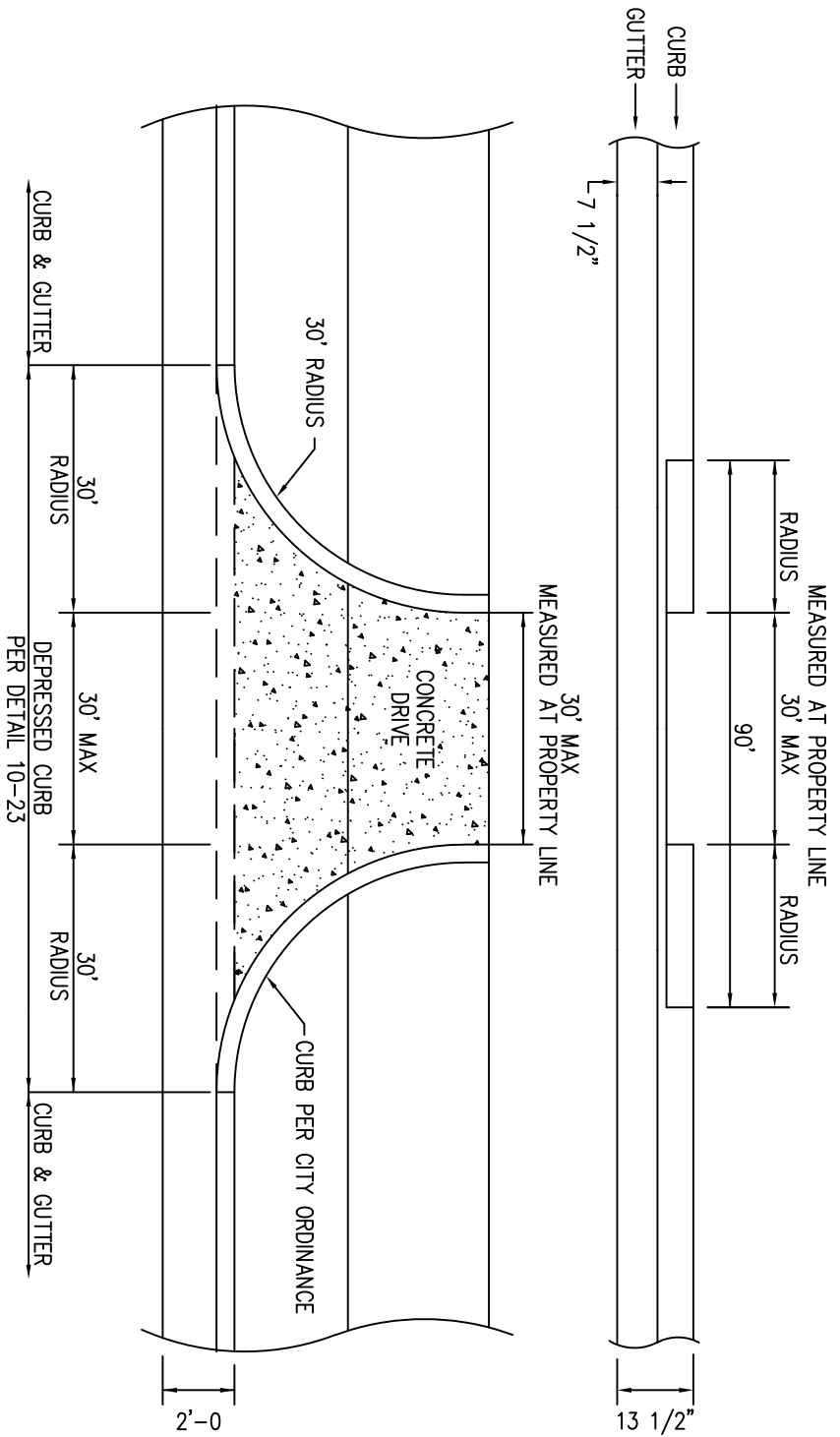

COMMERCIAL DRIVEWAYS

NO SCALE

NOTES:

- USE FOR DRIVES WITH ALL CURB TYPES EXCEPT ROLL CURB
- CONCRETE DRIVE AND/OR SIDEWALK ACROSS DRIVE SHALL BE MINIMUM OF 8" CONCRETE, 6" COMPACTED AGGREGATE, NO. 53 AND REINFORCED AS NEEDED BASED ON TRAFFIC EXPECTED TO ACCESS SITE.
- ANY EXISTING CURB, SHALL BE SAWCUT AT THE NEAREST JOINT TO THE REMOVAL LIMITS AND THE EXISTING CURB REMOVED.
- PROVIDE 30' RADIUS REGARDLESS OF SIDEWALK/PATH LOCATION
- PATH/SIDEWALK AND TREE LAWN DIMENSIONS VARY PER CARMEL CLAY COMPREHENSIVE PLAN (C3 PLAN)

STANDARD
DRAWING
10-22

CITY OF CARMEL STANDARDS
COMMERCIAL DRIVEWAY DEPRESSED CURB

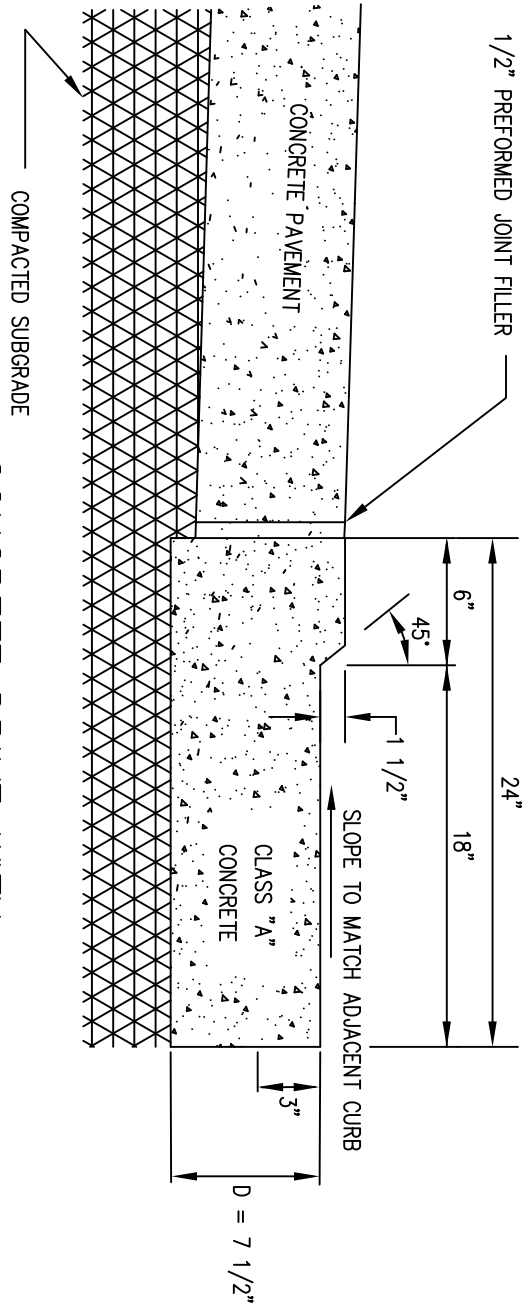

*CONCRETE DRIVE WITH
COMBINED DEPRESSED CURB AND GUTTER*

NO SCALE

- NOTES:
- CURING COMPOUND SHALL BE PLACED ON ALL EXPOSED SURFACES, INCLUDING SIDES, WHEN FORMS ARE REMOVED.
 - FACES MAY BE BATTERED TO FACILITATE SLIP FORMING.
 - DAMPEN SUBGRADE PRIOR TO PLACING CONCRETE.
 - CONTROL JOINTS SAWCUT EVERY 5' MAXIMUM ON RADII OTHERWISE EVERY 10' MAXIMUM WITH PREFORMED EXPANSION JOINT EVERY 50'
 - ALL ROADS FACE OF CURB IS TO BE 7 1/2", BACK OF CURB 13 1/2".

STANDARD
DRAWING
10-23

CITY OF CARMEL STANDARDS

CONCRETE DRIVE WITH DEPRESSED CURB AND GUTTER

EDGES TO BE SAWCUT AND CLEAN OF DEBRIS AND LOOSE ASPHALT BEFORE PATCHING

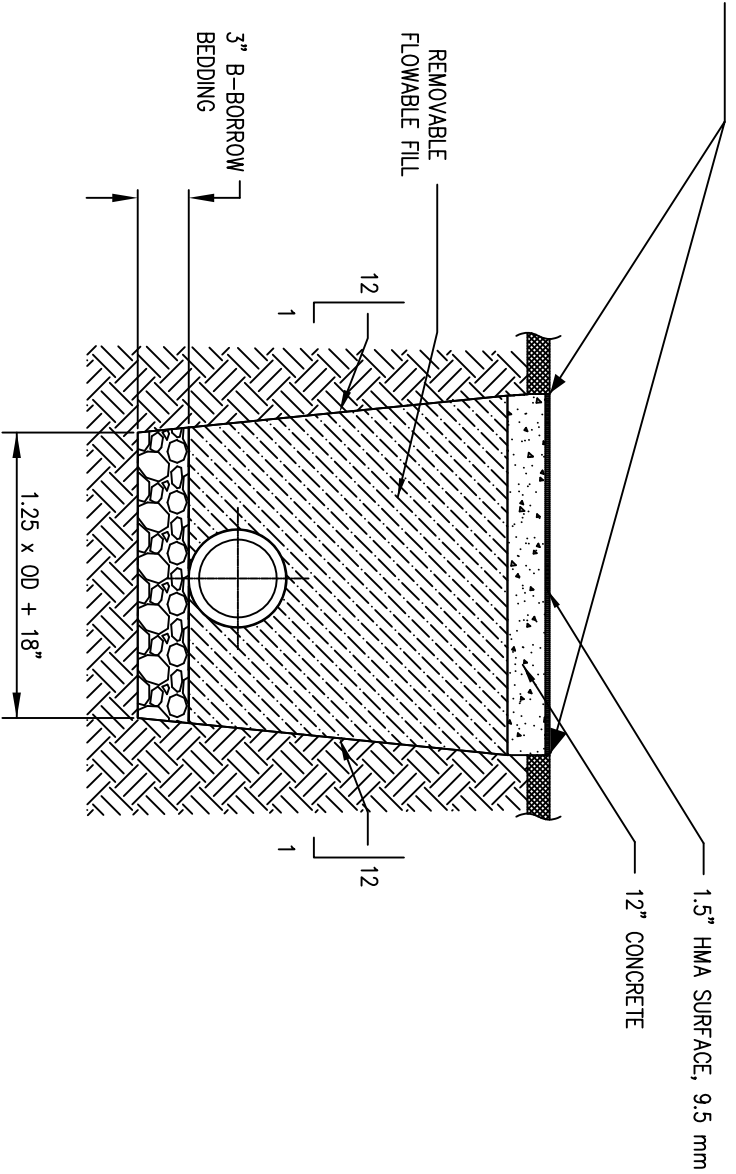

MULTI-USE PATH AND STREET CUT REPAIR DETAIL

NO SCALE

NOTES:

1. TRENCH SPOIL IS TO BE REMOVED FROM WORK SITE AND DISPOSED OF OUT OF THE RIGHT-OF-WAY
2. FLOWABLE FILL IS TO SERVE AS BACKFILL TO THE DIMENSION LISTED IN THIS DETAIL
3. THE EXISTING PAVEMENT IS TO BE TACK COATED PRIOR TO THE LAYING OF NEW ASPHALT. TACK COAT IS TO BE APPLIED AS SPECIFIED IN THE LATEST STANDARD OF INDOT SPECIFICATIONS, SECTION 406
4. THE NEW SURFACE IS TO BE SLOPED AT THE SAME RATE AS THE EXISTING SURFACE. ASPHALT TYPE SHALL MATCH ROAD CLASSIFICATION REQUIREMENTS.
5. FLOWABLE FILL SHALL CONFORM TO INDOT SPECIFICATION SECTION 213
6. IF PIPE IS PLASTIC OR HDPE: HAUNCHING AND INITIAL BACKFILL SHALL BE PER MANUFACTURER'S OR UTILITY RECOMMENDATIONS (TYP. #8 STONE TO 12" ABOVE TOP OF PIPE). FINAL BACKFILL SHALL BE FLOWABLE FILL UP TO 12" CONCRETE CAP.

STANDARD DRAWING
10-24

CITY OF CARMEL STANDARDS
MULTI-USE PATH AND STREET CUT REPAIR DETAIL

NOTES:

TRUCK APRON JOINTS SHALL BE RADIAL TO THE CENTER

POINT OF THE ROUNDABOUT IN A 24" GRID PATTERN

TRUCK APRON TO BE 7" OF CLASS 'A' CONCRETE ON MINIMUM OF 7" COMPACTED AGGREGATE NO 53. ON INDOT SUBGRADE TREATMENT IB OR IC

CONCRETE TO BE BROOM FINISHED PERPENDICULAR TO ROAD

TO BE IMPLEMENTED AS DIRECTED BY CITY ENGINEER. CONCRETE COLOR TO SLATE GREEN (PER TS FOR CONCRETE COLORING AND JOINTING) UNLESS OTHERWISE DIRECTED BY THE CITY OF CARMEL DEPARTMENT OF ENGINEERING.

TYPE D-1 CONTRACTION JOINTS NOT REQUIRED UNLESS OTHERWISE DIRECTED BY THE CITY OF CARMEL ENGINEERING DEPARTMENT.

TRUCK APRON RADIAL JOINT DETAIL

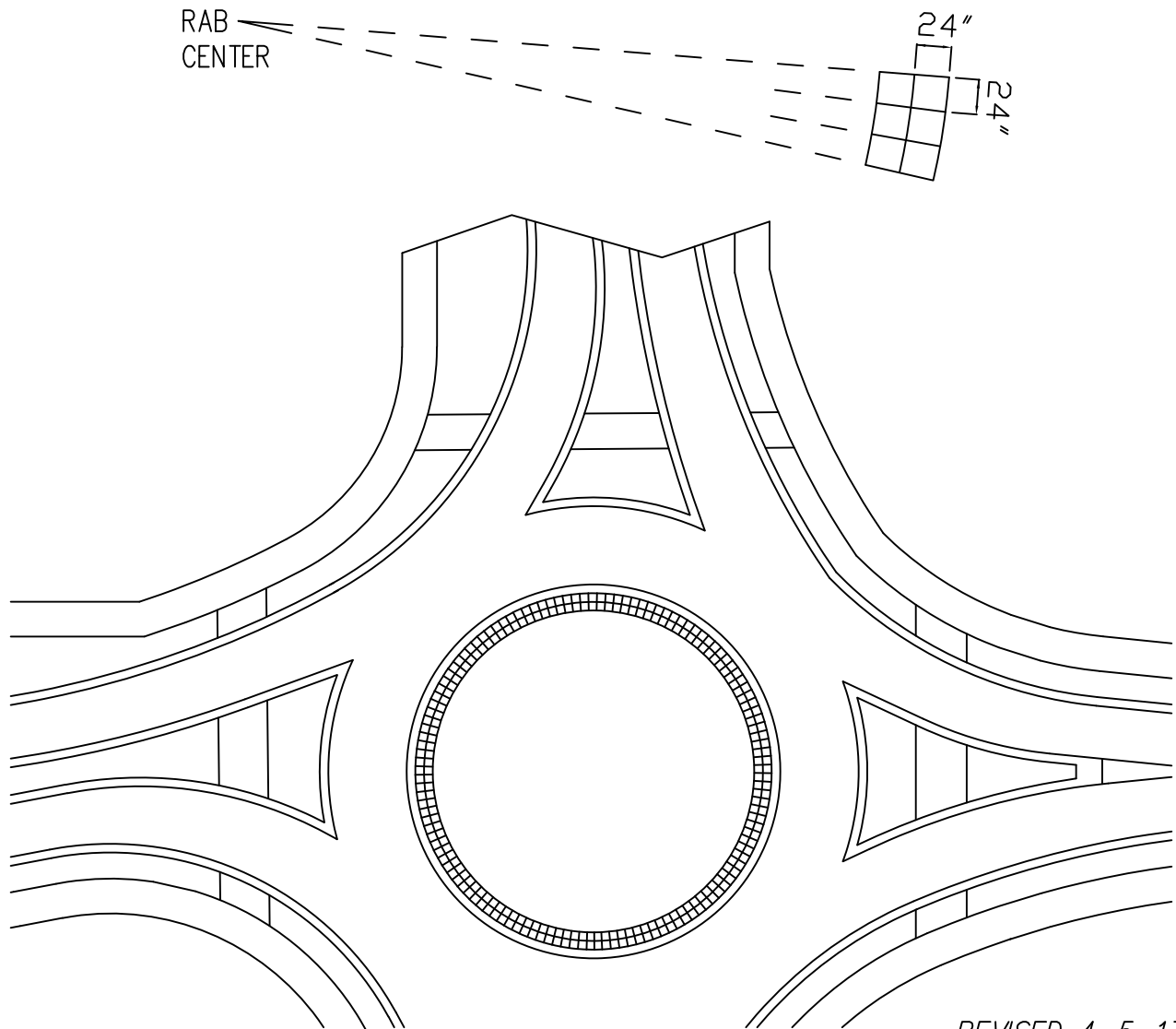

REVISED 4-5-17

STANDARD
DRAWING
10-25A

CITY OF CARMEL STANDARDS

COLORED CONCRETE PATTERN DETAIL

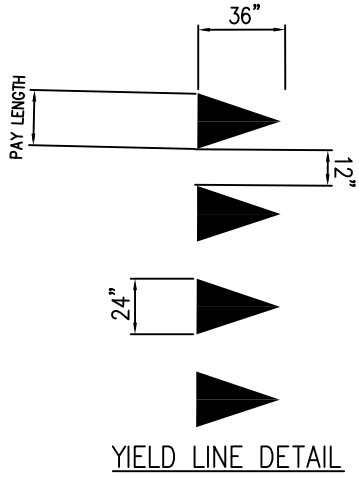
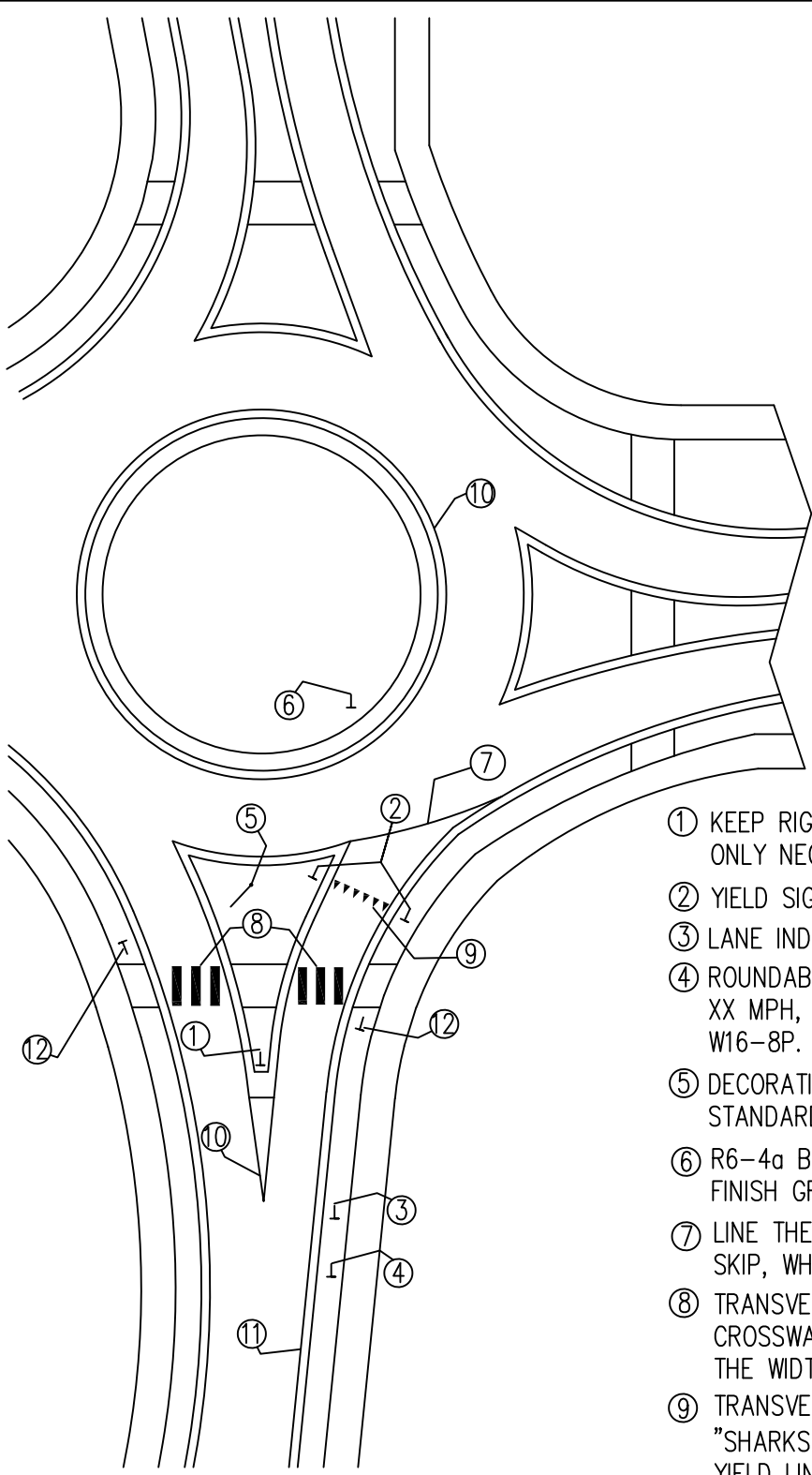

- ① KEEP RIGHT, R4-7
ONLY NECESSARY AT SPLITTER ISLANDS
- ② YIELD SIGN, R1-2
- ③ LANE INDICATION ARROW SIGN R3-8
- ④ ROUNDABOUT SYMBOL, W2-6
XX MPH, W13-1P, STREET NAME
W16-8P.
- ⑤ DECORATIVE STREET NAME SIGN SEE
STANDARD DRAWING 11A & 11B.
- ⑥ R6-4a BOTTOM OF SIGN 4' ABOVE
FINISH GRADE
- ⑦ LINE THERMOPLASTIC, 2' DASH, 2'
SKIP, WHITE, 8 INCH
- ⑧ TRANSVERSE MARKING, THERMOPLASTIC,
CROSSWALK, WHITE, 24 INCH AND EXTEND
THE WIDTH OF THE CURB RAMP.
- ⑨ TRANSVERSE MARKING, THERMOPLASTIC,
"SHARKS TEETH", YIELD LINE, WHITE, SEE
YIELD LINE DETAIL
- ⑩ LINE, THERMOPLASTIC, SOLID, YELLOW, 4IN.
- ⑪ LINE, THERMOPLASTIC, SOLID, WHITE, 4IN.
- ⑫ PEDESTRIAN CROSSING W11-2, W16-7P

NOTES:
SIGNAGE AND PAVEMENT MARKINGS
SHALL BE IN ACCORDANCE WITH
MOST RECENT VERSION OF MUTCD.

REVISED 3-22-17

STANDARD
DRAWING
10-25B

CITY OF CARMEL STANDARDS

ROUNDABOUT SIGNAGE DETAIL

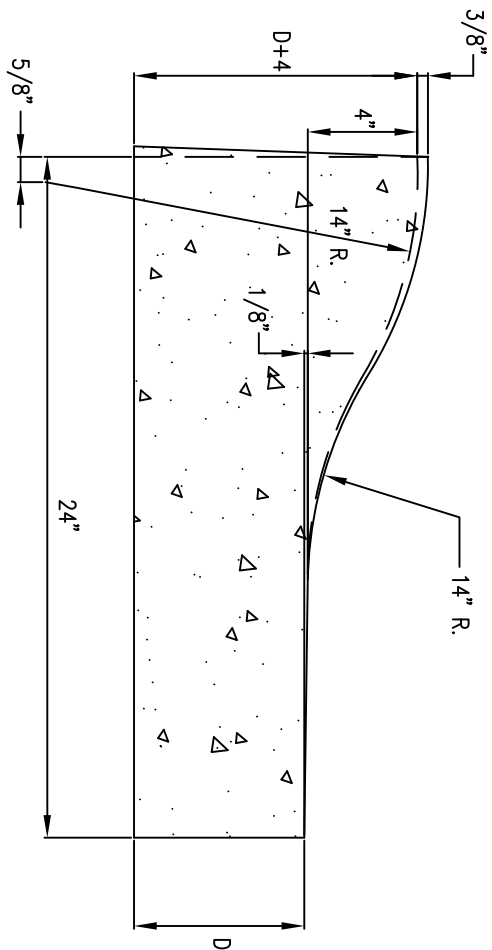

ROLL CURB FOR TRUCK APRON

NO SCALE

NOTES:

INTEGRAL CURB WITH CONCRETE PAVEMENT SHALL BE SIMILAR SHAPE

CURE ALL EXPOSED SURFACES

CONTRACTION JOINTS SHALL BE SAWCUT IN CONTINUOUSLY POURED CURBS TO A MINIMUM DEPTH OF 1/3"D

DAMPEN SUBGRADE BEFORE PLACING CONCRETE

CONTROL JOINTS EVERY 5' MAXIMUM ON RADII OTHERWISE EVERY 10', MAXIMUM. PREFORMED EXPANSION JOINTS MAXIMUM EVERY 50'

NO BACKFILLING OR COMPACTION MAY OCCUR 12' FROM CURB UNTIL 5 FULL DAYS HAVE PASSED AFTER PLACING CONCRETE

SHALL BE INSTALLED IN ACCORDANCE WITH INDOT STANDARD SPECIFICATIONS

STANDARD
DRAWING
10-25C

CITY OF CARMEL STANDARDS

ROLL CURB FOR TRUCK APRON

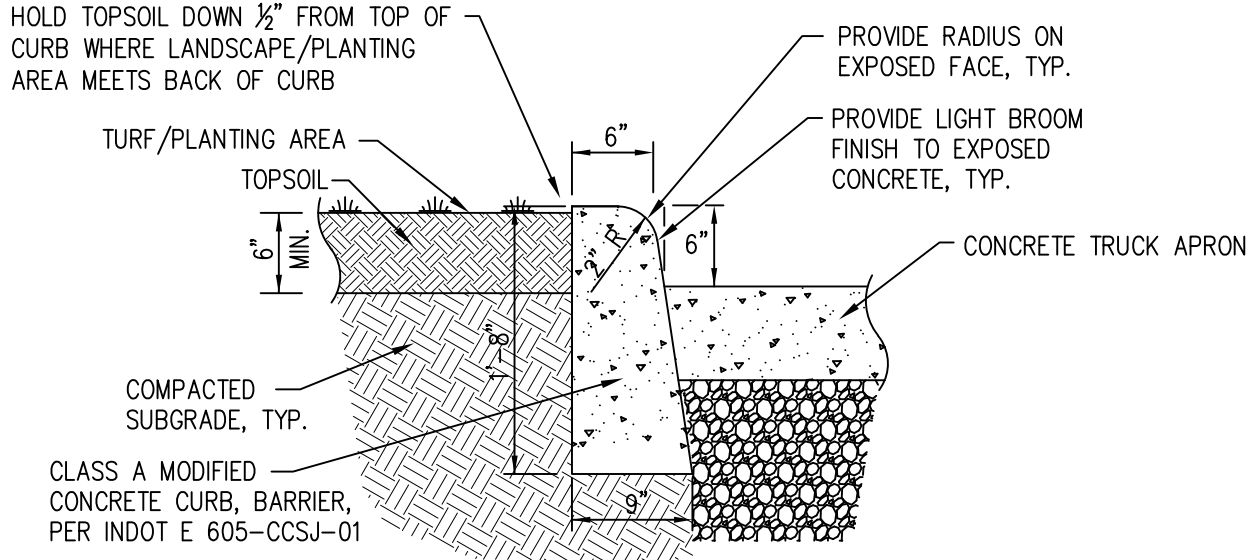

BARRIER CURB AT TRUCK APRON
NO SCALE

NOTE:
PROVIDE SAWCUT CONTROL JOINT FOR EVERY 6' - ALIGN
CONTROL JOINTS W/EVERY THIRD (3RD) JOINT ON TRUCK APRON

STANDARD
DRAWING
10-25D

CITY OF CARMEL STANDARDS

BARRIER CURB AT RAB TRUCK APRON DETAIL

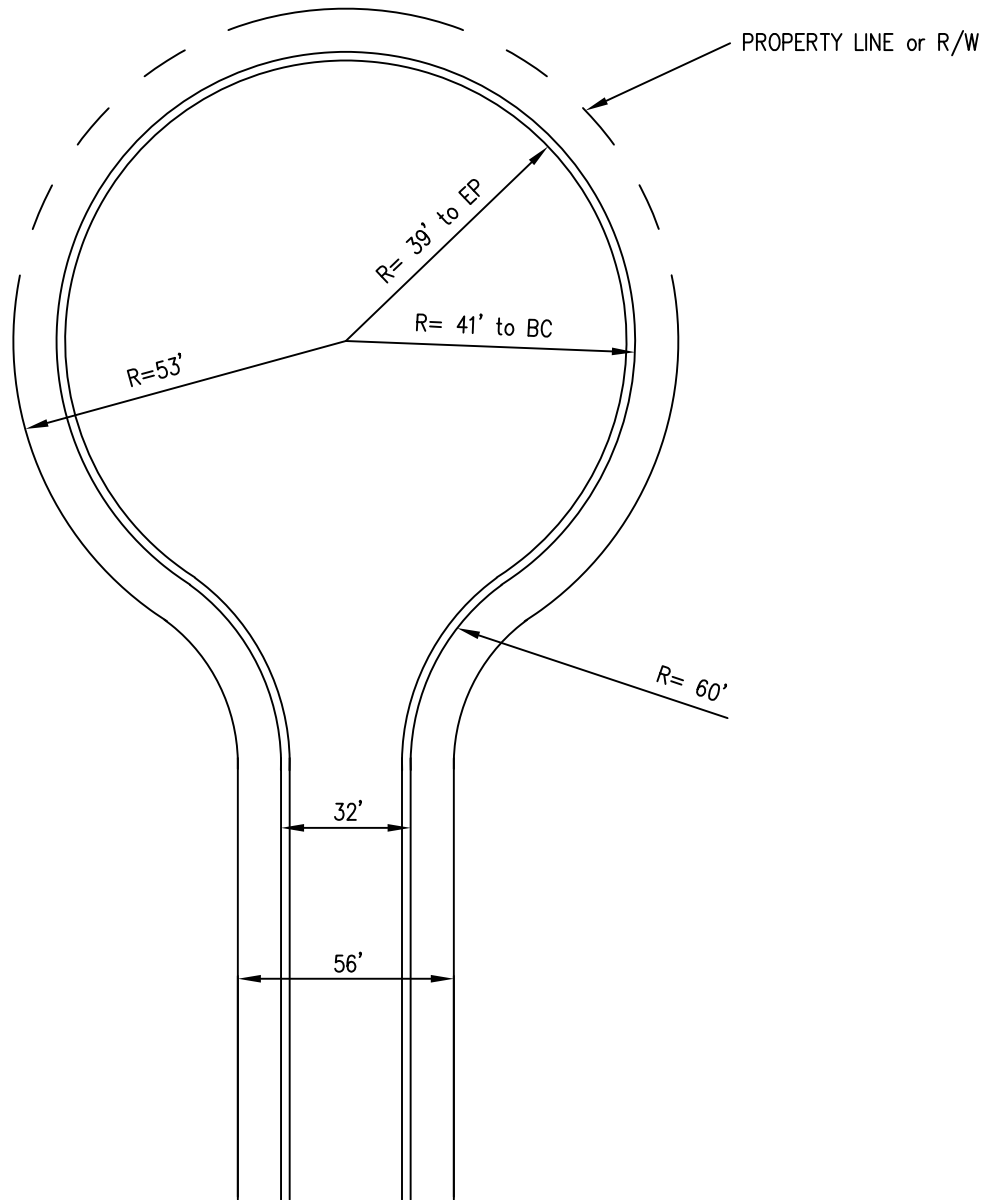

SUBDIVISION CUL-DE-SAC

NO SCALE

NOTES:

1. ELEVATIONS PROVIDED SHALL BE PROPOSED FLOW LINE OF GUTTER
2. ONE DETAIL SHALL BE PROVIDED FOR EACH CUL-DE-SAC AND INCLUDED IN THE CONSTRUCTION DRAWINGS
3. SCALE SHALL BE 1"= 40' OR LARGER
4. CENTER OF CUL-DE-SAC TO CENTERLINE OF INTERSECTING STREET SHALL NOT EXCEED 600'

STANDARD
DRAWING
10-26

CITY OF CARMEL STANDARDS

SUBDIVISION CUL-DE-SAC 'A'

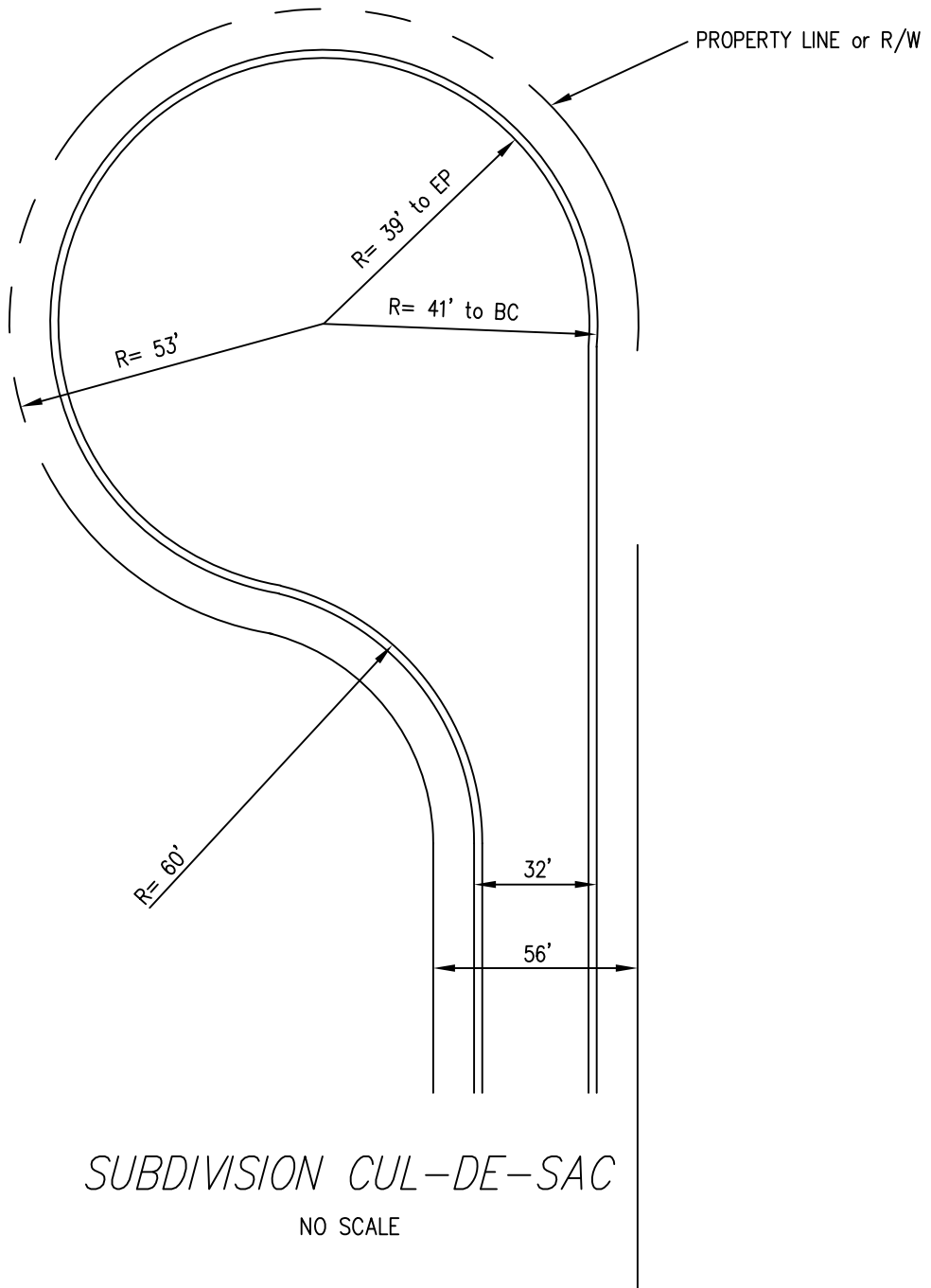

SUBDIVISION CUL-DE-SAC

NO SCALE

NOTES:

1. ELEVATIONS PROVIDED SHALL BE PROPOSED FLOW LINE OF GUTTER
2. ONE DETAIL SHALL BE PROVIDED FOR EACH CUL-DE-SAC AND INCLUDED IN THE CONSTRUCTION DRAWINGS
3. SCALE SHALL BE 1"= 40' OR LARGER
4. CENTER OF CUL-DE-SAC TO CENTERLINE OF INTERSECTING STREET SHALL NOT EXCEED 600'

STANDARD
DRAWING
10-27

CITY OF CARMEL STANDARDS

SUBDIVISION CUL-DE-SAC 'B'

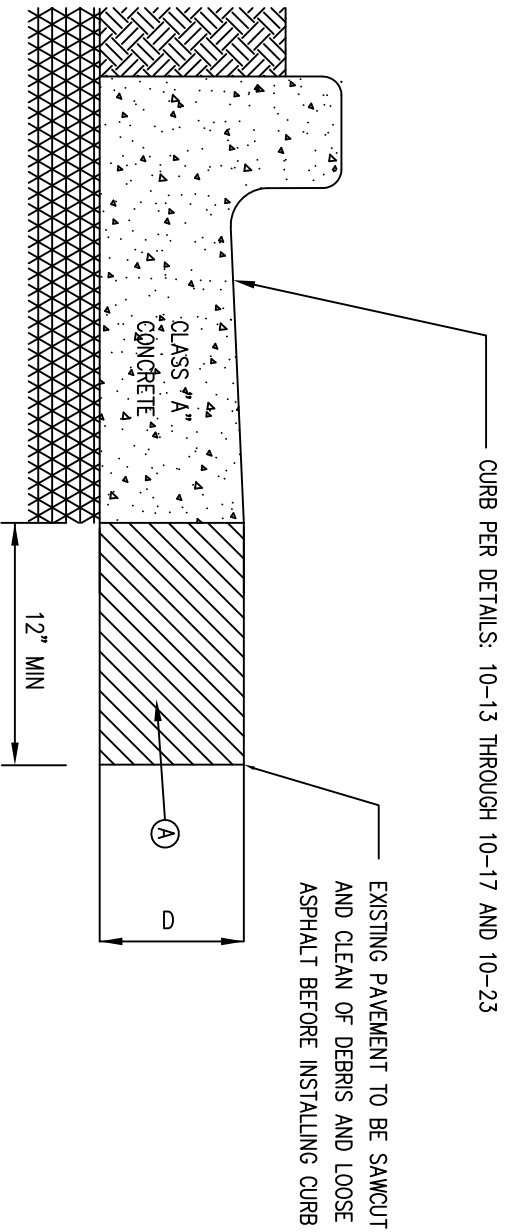

INSTALLING CURB ADJACENT TO EXISTING PAVEMENT

NO SCALE

NOTES:

INTEGRAL CURB WITH CONCRETE PAVEMENT SHALL BE SIMILAR SHAPE

CURE ALL EXPOSED SURFACES

CONTRACTION JOINTS SHALL BE SAWCUT IN CONTINUOUSLY POURED CURBS TO A MINIMUM DEPTH OF 1/3" D

DAMPEN SUBGRADE BEFORE PLACING CONCRETE

CONTROL JOINTS SAWCUT EVERY 5' MAXIMUM ON RADI OTHERWISE EVERY 10' MAXIMUM. PREFORMED EXPANSION JOINTS EVERY 50' MAXIMUM

NO BACKFILLING OR COMPACTION MAY OCCUR 12' FROM CURB UNTIL 5 FULL DAYS HAVE PASSED AFTER PLACING CONCRETE

EXISTING UNDERDRAIN AND FILTER FABRIC AND STONE DRAINAGE ENVELOPE SHALL BE PRESERVED

Ⓐ CONCRETE CAP SHALL BE INSTALLED WITHIN 1 1/2" EXISTING ADJACENT GRADE, 1 1/2" OF HMA SURFACE, 9.5 mm SHALL BE INSTALLED TO MATCH EXISTING GRADES
 CONCRETE SHALL BE INSTALLED IN ACCORDANCE WITH INDOT STANDARD SPECIFICATIONS.

STANDARD
DRAWING
10-28

CITY OF CARMEL STANDARDS
 INSTALL CURB ADJACENT TO EXISTING PAVEMENT

AFTER FUTURE CONNECTION HAS BEEN MADE POST SHALL BE CUT BELOW GRADE AND REMAIN.

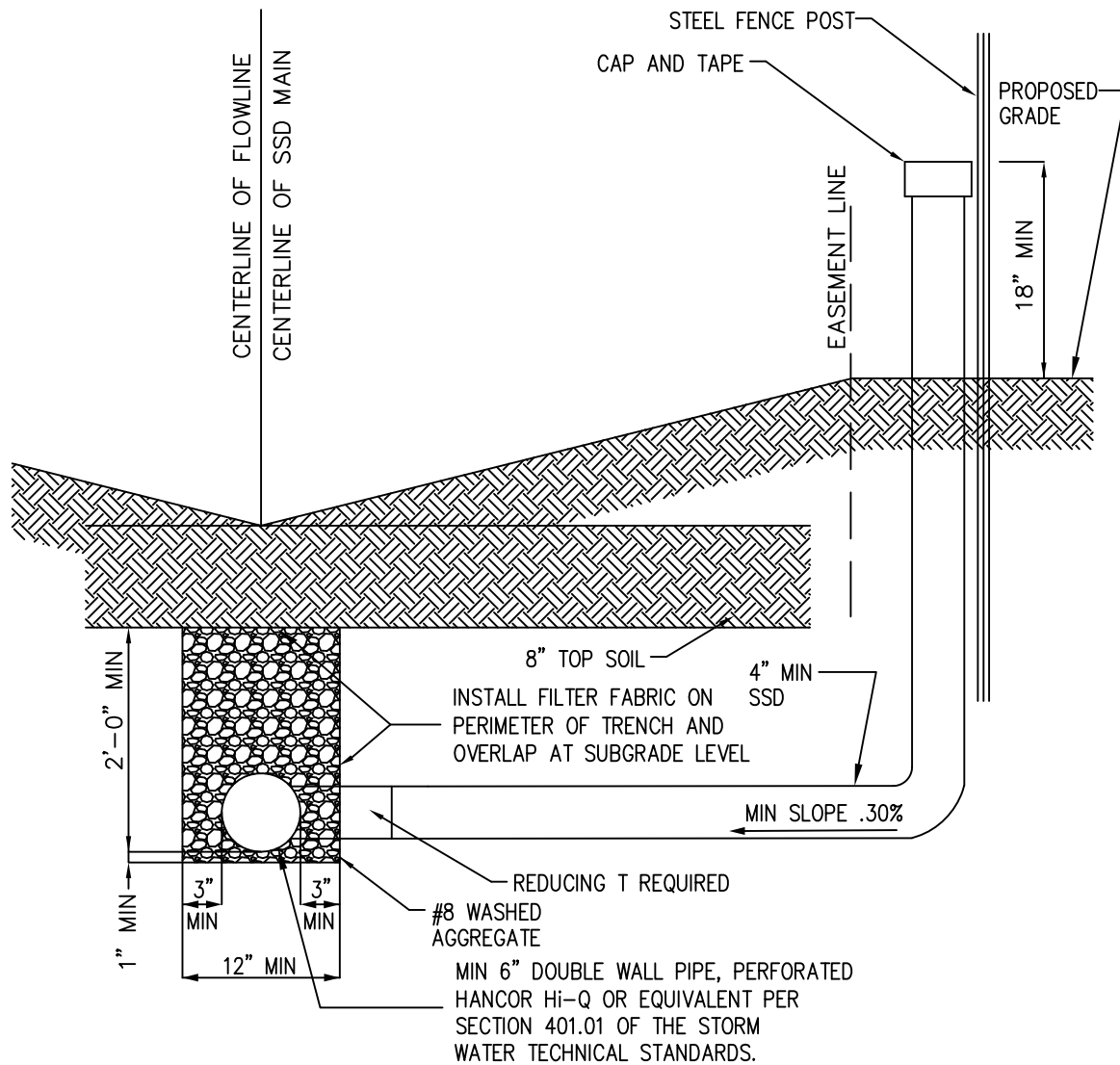

SSD LATERAL TO INDIVIDUAL LOTS IN REAR YARD
NO SCALE

NOTES:

PIPE SHALL CONFORM TO SPEC REQUIREMENTS OF SECTION 907 OF STANDARD SPECIFICATION

TEMPORARY EXTENSION ABOVE GROUND TO BE REMOVED UPON CONNECTION TO HOUSE

STANDARD
DRAWING
10-29A

CITY OF CARMEL STANDARDS

TYPICAL SSD LATERAL TO INDIVIDUAL LOTS IN REAR YARD

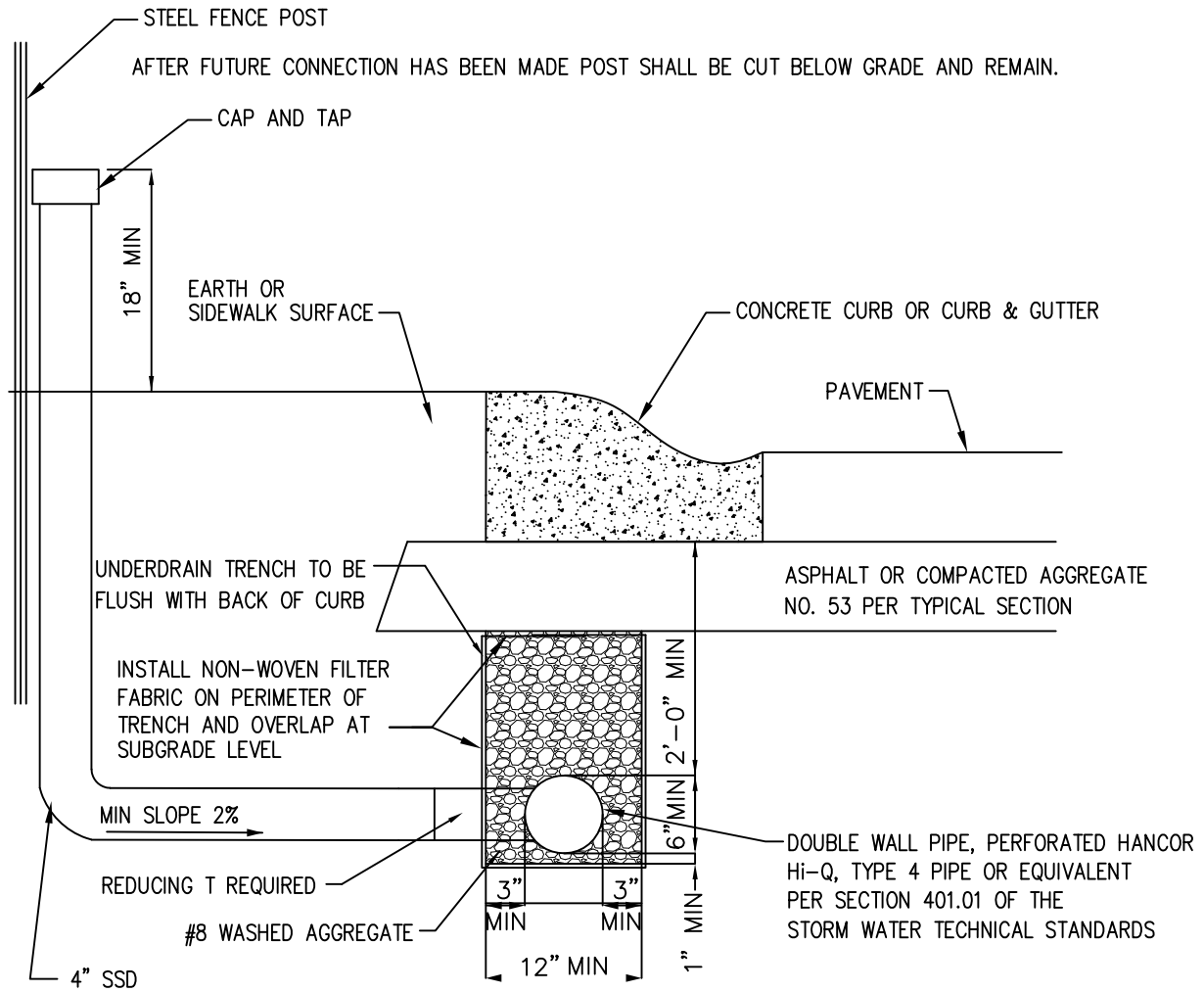

TYPICAL SSD LATERAL TO INDIVIDUAL LOTS UNDER CONCRETE CURB.

NO SCALE

NOTES:

PIPE SHALL CONFORM TO SPEC REQUIREMENTS OF SECTION 907 OF STANDARD SPECIFICATION

TEMPORARY EXTENSION ABOVE GROUND TO BE REMOVED UPON CONNECTION TO HOUSE

STANDARD
DRAWING
10-29B

CITY OF CARMEL STANDARDS

TYPICAL SSD TO INDIVIDUAL LOTS UNDER CONCRETE CURB

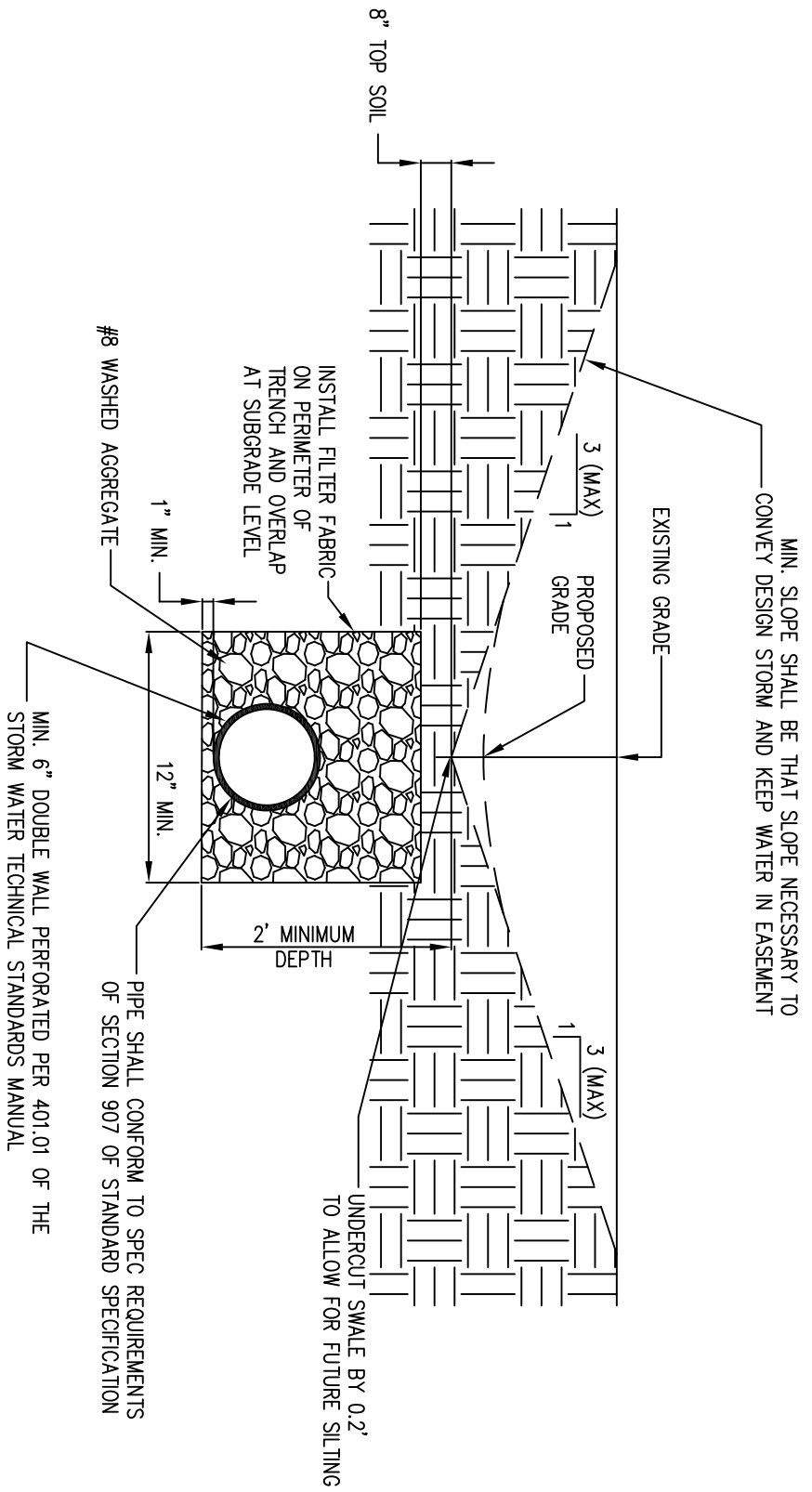

TYPICAL SWALE DETAIL

NO SCALE

STANDARD DRAWING 10-30

CITY OF CARMEL STANDARDS

TYPICAL SWALE DETAILS

TRENCH DETAIL FOR CITY STORM SEWERS

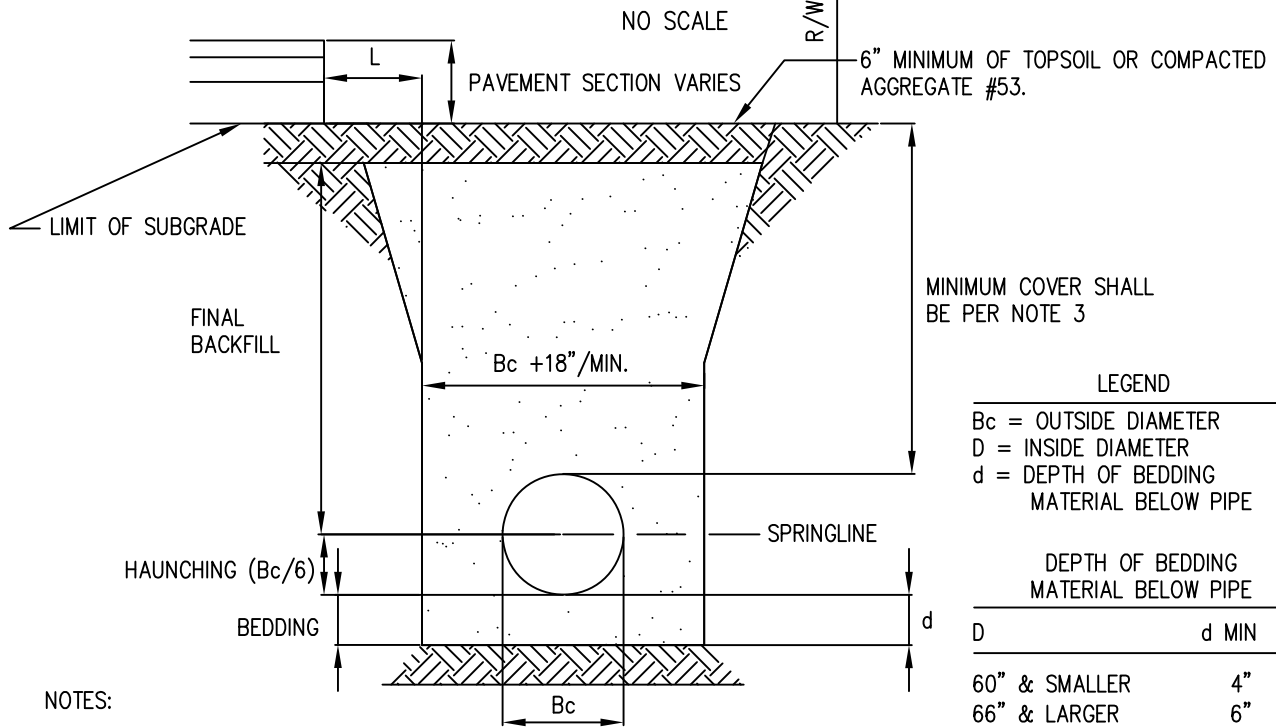

1. BEDDING AND HAUNCHING FOR ALL RCP INSTALLATIONS SHALL BE #8 STONE MEETING THE MATERIAL REQUIREMENTS OF THE INDOT. BEDDING SHALL BE PLACED IN THE TRENCH BOTTOM SUCH THAT AFTER THE PIPE IS INSTALLED TO GRADE AND LINE, THERE REMAINS A 4" MINIMUM DEPTH OF MATERIAL BELOW THE PIPE BARREL AND A MINIMUM OF 3" BELOW THE BELL. FOR PIPE SIZES 66" AND LARGER, THE MINIMUM DEPTH OF MATERIAL BELOW THE PIPE BAREL SHALL BE 6". BEDDING SHALL BE PLACED TO BE UNIFORM AS POSSIBLE, BUT SHALL BE LOOSELY PLACED UNCOMPACTED MATERIAL UNDER THE MIDDLE THIRD OF THE PIPE PRIOR TO PLACEMENT OF THE PIPE. IF THE UNDERLYING SOILS OF THE TRENCH BOTTOM ARE SOFT OR YIELDING, THE SOIL SHALL BE UNDERCUT TO SUCH A DEPTH THAT WHEN REPAIRED WITH #2 STONE IT WILL PRODUCE A UNIFORM AND STABLE FOUNDATION ALONG THE ENTIRE LENGTH OF THE PIPE. HAUNCHING AND INITIAL BACKFILL SHALL BE COMPACTED IN 8" MAXIMUM LIFTS TO NOT LESS THAN 90% STANDARD PROCTOR DENSITY FOR THE ENTIRE DEPTH OF THE MATERIAL PLACED. THE BACKFILL SHALL BE BROUGHT UP EVENLY ON BOTH SIDES OF THE PIPE FOR THE FULL LENGTH OF THE PIPE. HAUNCHING SHALL EXTEND TO THE SPRINGLINE OF THE PIPE. MINIMUM TRENCH WIDTH SHALL BE THE OUTSIDE DIAMETER OF THE PIPE PLUS 18".
2. FINAL BACKFILL FOR ALL RCP INSTALLATIONS WHERE "L" IS 5' OR LESS SHALL BE B-BORROW FOR STRUCTURE BACKFILL MEETING THE MATERIAL REQUIREMENTS OF THE INDOT AND SHALL BE COMPACTED IN 6" MAXIMUM LIFTS TO NOT LESS THAN 95% STANDARD PROCTOR DENSITY FOR THE ENTIRE DEPTH OF THE MATERIAL PLACED. THE BACKFILL FOR THE TOP 6" OF THE EXCAVATION BELOW THE LIMIT OF SUBGRADE SHALL BE #53 STONE MEETING THE MATERIAL REQUIREMENTS OF THE INDOT AND SHALL BE COMPACTED TO NOT LESS THAN 95% STANDARD PROCTOR DENSITY. FINAL BACKFILL FOR ALL RCP INSTALLATIONS WHERE "L" IS GREATER THAN 5' SHALL BE CLEAN FILL MATERIAL FREE OF ROCKS LARGER THAN 6" IN DIAMETER, FROZEN LUMPS OF SOIL, WOOD OR OTHER EXTRANEIOUS MATERIAL, COMPACTED IN 12" MAXIMUM LIFTS TO NOT LESS THAN 90% STANDARD PROCTOR DENSITY FOR THE ENTIRE DEPTH OF THE EXCAVATION. CONTRACTOR SHALL PROVIDE A 3rd PARTY TESTING AGENCY TO PROVIDE COMPACTION TESTING AS NECESSARY.
3. FOR INSTALLATION OF STORM MAINS, WATERMAINS, SANITARY MAINS, WATER SERVICE LATERALS, AND SANITARY SERVICE LATERALS UNDER CITY STREETS, REGARDLESS OF THE JURISDICTION OF THE UTILITY, THE MINIMUM COVER FROM THE TOP OF THE INSTALLED PAVEMENT OR FINAL GROUND ELEVATION TO THE TOP OF THE INSTALLED PIPE SHALL BE NO LESS THAN 2.5 FEET OF COVER ALONG ANY PART OF THE PIPE. IF THE STANDARD PRACTICE OF THE UTILITY THAT HAS JURISDICTION OVER THE INSTALLATION HAS A MORE STRINGENT COVER REQUIREMENT, THE MORE STRINGENT REQUIREMENT SHALL GOVERN.
4. IF EXISTING SUBGRADE HAS BEEN LIME STABILIZED, BACKFILL WITH B-BORROW TO BOTTOM OF EXISTING SUBGRADE AND FILL TO THE LIMIT OF EXISTING SUBGRADE WITH COMPACTED AGGREGATE NO 53.
5. THESE STANDARDS SHALL APPLY FOR STORM SEWERS INSTALLED WITHIN EXISTING AND PROPOSED CITY R/W AND FOR STORM SEWERS THAT SHALL BE MAINTAINED BY THE CITY, REGARDLESS OF STORM SEWER JURISDICTION.
6. ALL STORM PIPE WITHIN EXISTING OR PROPOSED CITY R/W SHALL BE REINFORCED CONCRETE PIPE REGARDLESS OF JURISDICTION OVER STORM PIPES.

STANDARD
DRAWING
10-31

CITY OF CARMEL STANDARDS

TRENCH DETAIL FOR CITY STORM SEWERS

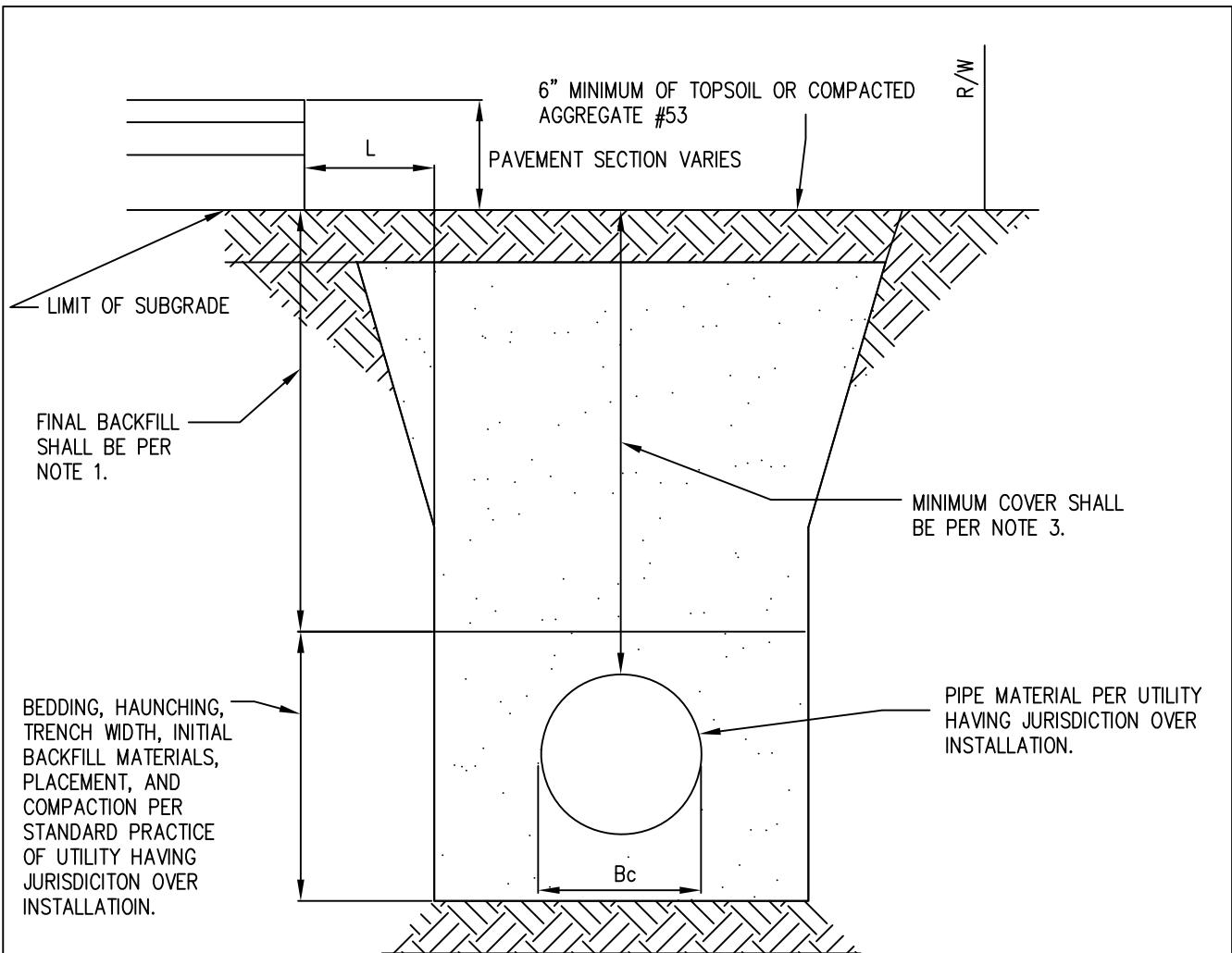

*WATER & SEWER MAIN AND LATERAL TRENCH DETAIL
FOR UTILITY INSTALLATIONS WITHIN CITY R/W*

NO SCALE

NOTES:

1. FINAL BACKFILL FOR UTILITY INSTALLATIONS WHERE "L" IS 5' OR LESS SHALL BE B-BORROW FOR STRUCTURE BACKFILL MEETING THE MATERIAL REQUIREMENTS OF THE INDOT AND SHALL BE COMPACTED IN 6" MAXIMUM LIFTS TO NOT LESS THAN 95% STANDARD PROCTOR DENSITY FOR THE ENTIRE DEPTH OF THE MATERIAL PLACED. THE BACKFILL FOR THE TOP 6" OF THE EXCAVATION BELOW THE LIMIT OF SUBGRADE SHALL BE #53 STONE MEETING THE MATERIAL REQUIREMENTS OF THE INDOT AND SHALL BE COMPACTED TO NOT LESS THAN 95% STANDARD PROCTOR DENSITY FOR THE ENTIRE DEPTH OF THE MATERIAL PLACED. IF THE STANDARD PRACTICE OF THE UTILITY THAT HAS JURISDICTION OVER THE INSTALLATION HAS A MORE STRINGENT FINAL BACKFILL REQUIREMENT, THE MORE STRINGENT REQUIREMENT WILL GOVERN. CONTRACTOR SHALL PROVIDE A 3rd PARTY TESTING AGENCY TO PROVIDE COMPACTION TESTING AS NECESSARY.
2. THIS REQUIREMENT SHALL APPLY FOR ALL UTILITY INSTALLATIONS (INCLUDING BUT NOT LIMITED TO WATER MAINS, WATER SERVICE LATERALS, SANITARY MAINS, SANITARY SERVICE LATERALS, GAS PIPING, POWER, TELECOMM AND CATV CONDUITS OR DUCT BANK) WITHIN EXISTING AND PROPOSED CITY OF CARMEL R/W LIMITS.
3. FOR UTILITY INSTALLATIONS UNDER CITY STREETS, REGARDLESS OF THE JURISDICTION OF THE UTILITY, THE MINIMUM COVER FROM THE TOP OF THE INSTALLED PAVEMENT OR FINAL GROUND ELEVATION TO THE TOP OF THE INSTALLED PIPE CONDUIT OR DUCT BANK SHALL BE NO LESS THAN 2.5 FEET. IF THE STANDARD PRACTICE OF THE UTILITY THAT HAS JURISDICTION OVER THE INSTALLATION HAS A MORE STRINGENT COVER REQUIREMENT, THE MORE STRINGENT REQUIREMENT SHALL GOVERN.
4. IF EXISTING SUBGRADE HAS BEEN LIME STABILIZED, BACKFILL WITH B-BORROW TO BOTTOM OF EXISTING SUBGRADE AND FILL TO THE LIMIT OF TREATED SUBGRADE WITH COMPACTED AGGREGATE, NO 53.

STANDARD DRAWING 10-32	<i>CITY OF CARMEL STANDARDS</i>
	WATER & SEWER MAIN AND LATERAL TRENCH DETAIL FOR UTILITY INSTALLATIONS WITHIN CITY R/W

STANDARD INTERSECTION

NO SCALE

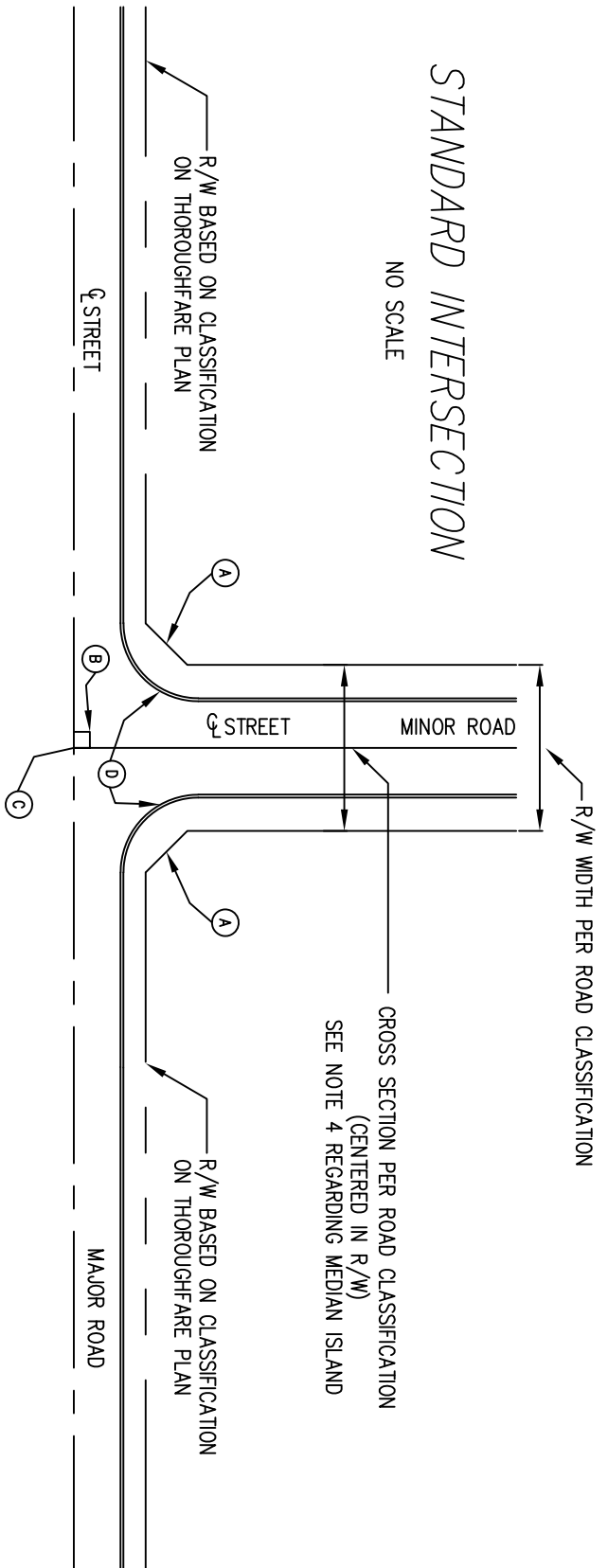

NOTES:

1. IF A ROUNDABOUT IS PLANNED AT INTERSECTION, ADEQUATE R/W SHALL BE PROVIDED AS REQUIRED BY THE DEPARTMENT OF ENGINEERING
2. WHERE SUBDIVISION ACCESS IS FROM A PRIMARY OR SECONDARY THOROUGHFARE, OR A COLLECTOR STREET, ACCELERATION/DECELERATION LANES AND A PASSING LANE SHALL BE PROVIDED AT EACH INTERSECTION. SEE STANDARD DRAWING 10-35 FOR DIMENSIONS.
3. INTERSECTION OFFSET POINT SHALL BE LOCATED SUCH THAT THE OPPOSING LEFT TURN LANES ARE ALIGNED.
4. MEDIAN ISLAND WILL ONLY BE APPROVED IF STANDARD CROSS SECTION BASED ON CLASSIFICATION OF MINOR ROADWAY ALLOWS FOR A MEDIAN ISLAND. IF MEDIAN ISLAND IS ALLOWED AND WILL BE INSTALLED, REFER TO MEDIAN ISLAND AT SUBDIVISION OR COMMERCIAL AREA ENTRANCE DETAIL FOR ADDITIONAL REQUIREMENTS.

- (A) 20' RADIUS INSCRIBED BY R/W LINES FOR LOCAL-LOCAL, TRIANGULAR AREA WITH TWO 30' SIDES FOR LOCAL-COLLECTOR OR TRIANGULAR AREA WITH TWO 50' SIDES FOR ARTERIAL/PARKWAY
- (B) ANGLE OF INTERSECTION OF MINOR ROAD SHALL BE 90 DEGREES WHEN POSSIBLE, BUT NOT LESS THAN 75 DEGREES. JUSTIFICATION SHALL BE PROVIDED IF ANGLE IS NOT 90 DEGREES.
- (C) INTERSECTION OFFSET POINT, FOR ACCESS FROM A MAJOR ROAD WHICH IS A COLLECTOR, PARKWAY OR ARTERIAL THIS POINT SHALL BE AT LEAST 500' FROM THE NEAREST MAJOR ROAD INTERSECTION WITH ANOTHER MAJOR OR MINOR ROAD. THIS POINT SHALL BE ALIGNED WITH AN EXISTING MINOR ROAD OR EXISTING ENTRANCE, COMMERCIAL ACCESS POINT WITHIN THE LIMITS OF THE FRONTAGE. IF ALIGNMENT IS NOT POSSIBLE, THE OFFSET DISTANCE BETWEEN THIS POINT AND SIMILAR POINT ON EXISTING ACCESS SHALL BE MAXIMIZED, BUT SHALL BE A MINIMUM OF 200' PROVIDED THAT THE 500' MINIMUM DISTANCE IS STILL SATISFIED. IF INTERSECTION IS WITHIN A LOCAL ROAD NETWORK AND ALIGNMENT WITH AN EXISTING COMMERCIAL ACCESS POINT OR MINOR ROAD IS NOT POSSIBLE, A MINIMUM 150' SEPARATION SHALL BE PROVIDED.
- (D) 20' LOCAL-LOCAL, 40' LOCAL-ALL OTHER

STANDARD
DRAWING
10-33

CITY OF CARMEL STANDARDS

STANDARD INTERSECTION

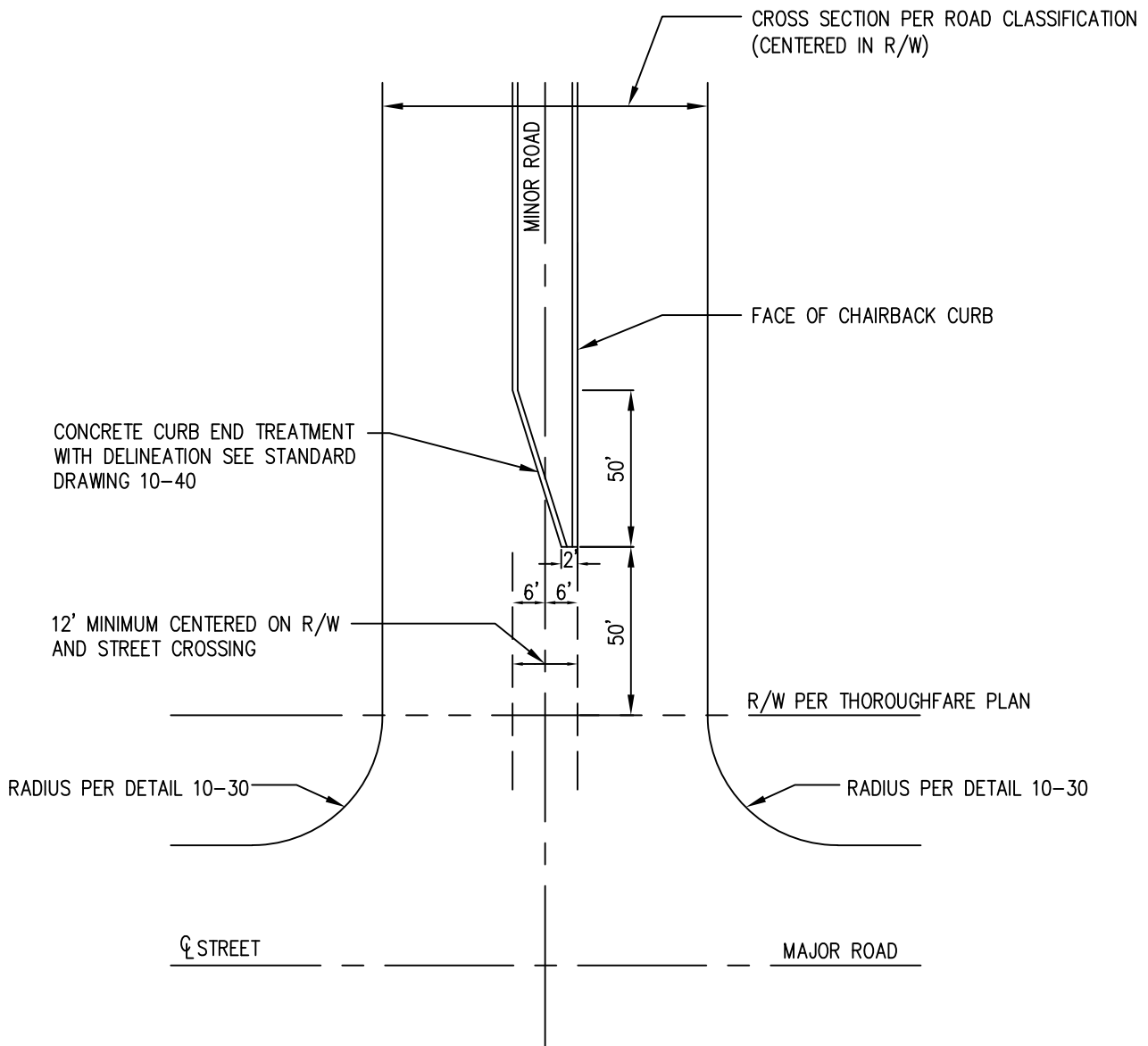

*MEDIAN ISLAND AT LOCAL ROAD
INTERSECTION WITH MAJOR ROAD*

NO SCALE

STANDARD
DRAWING
10-34

CITY OF CARMEL STANDARDS

MEDIAN ISLAND AT SUBDIVISION OR COMMERCIAL ENTRANCE

AUXILIARY LANES AND MAJOR ROAD IMPROVEMENTS

NO SCALE

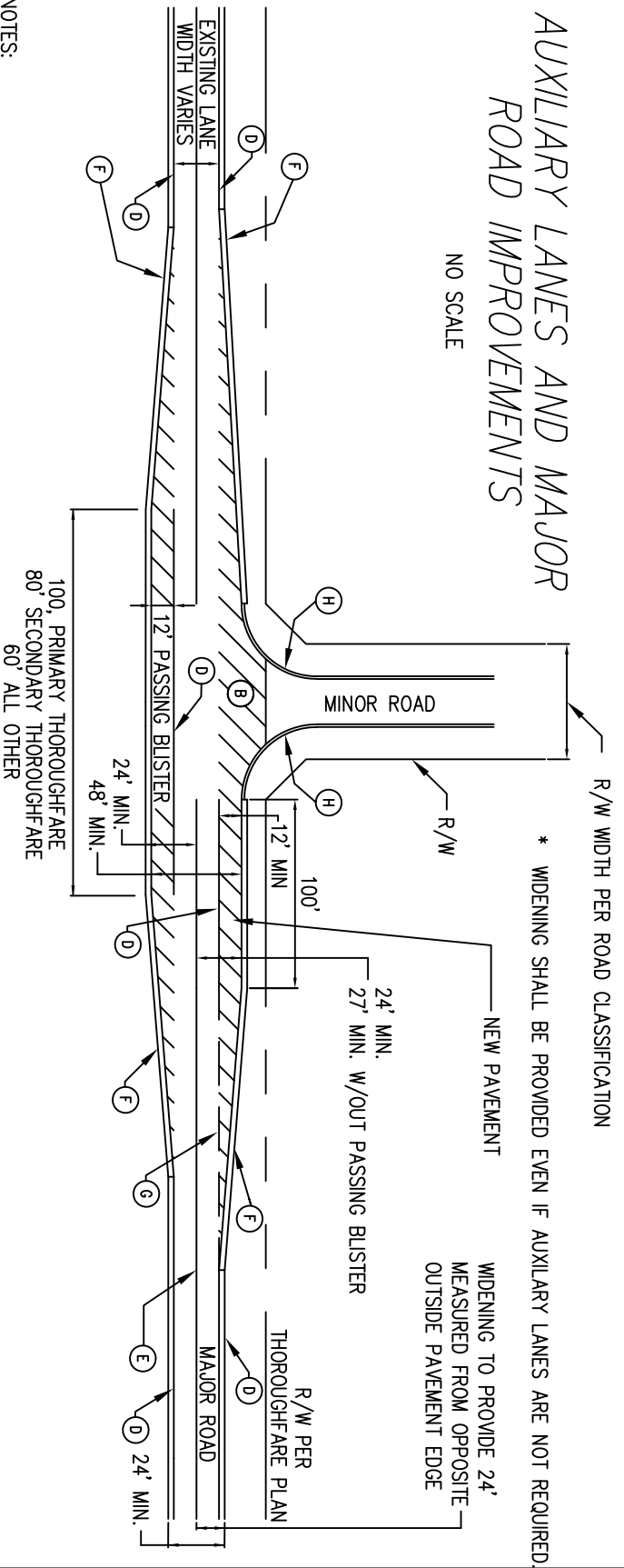

NOTES:

1. CONSTRUCTION PLANS SHALL INCLUDE CENTERLINE PROFILE OF EXISTING ROAD BEING INTERSECTED BY THE ENTRANCE. THE PROFILE SHALL EXTEND A MINIMUM OF 500' EACH DIRECTION FROM ENTRANCE CENTERLINE. LOCATION OF MINOR ROAD SHALL BE SUCH THAT SSD ON MAJOR ROAD IS PROVIDED.
2. THE CITY ENGINEER, AT ITS DISCRETION, MAY REQUIRE THE CONNECTION OF AUXILIARY LANES BETWEEN DEVELOPMENTS, EVEN IF WORK EXCEEDS THAT REQUIRED ON THIS DETAIL.
3. AUXILIARY LANES (ACCELERATION TAPER, DECELERATION TAPER, DECELERATION LANE AND PASSING BLISTER) ARE REQUIRED AT ALL SUBDIVISION ENTRANCES WHERE R/W EXISTS PURSUANT TO CITY OF CARMEL ORDINANCES.
4. MILL THE FULL WIDTH OF THE EXISTING PAVEMENT 1.5" AND RESURFACE WITH 1.5" HMA SURFACE, 9.5mm. WORK SHALL EXTEND ACROSS ENTIRE FRONTAGE OF PROPERTY OR TO LIMITS OF AUXILIARY LANES, WHICHEVER IS GREATER.
5. IF THESE DIMENSIONS CONFLICT WITH THE DIMENSIONS PRESENTED IN CITY OF CARMEL ORDINANCES, THE REQUIREMENTS RESULTING IN LARGER DIMENSIONS SHALL APPLY.
6. TAPER LENGTHS SHALL BE IN ACCORDANCE WITH MOST RECENT VERSION OF MUTCD.

- (B) PAVEMENT SECTION PER ROAD CLASSIFICATION BACK TO RIGHT OF WAY.
- (D) 4" THERMOPLASTIC SOLID WHITE
- (E) 4" THERMOPLASTIC DOUBLE YELLOW FOR ENTIRE RESURFACING AREA
- (F) 3", COMPACTED AGGREGATE #73 GRAVEL SHOULDER, 6" DEPTH. SSD MEETING CITY OF CARMEL DETAIL 10-12 SHALL BE INSTALLED UNDER SHOULDER AND CONNECTED TO ON-SITE STORM SEWER SYSTEM.
- (G) 4" THERMOPLASTIC, DOTTED, WHITE, 2' STRIPE - 2' GAP.
- (H) 40' MINIMUM RADIUS SHALL BE PROVIDED REGARDLESS OF MAJOR/MINOR ROAD CLASSIFICATION.

STANDARD
DRAWING
10-35

CITY OF CARMEL STANDARDS
AUXILIARY LANES AND MAJOR ROAD IMPROVEMENTS

AUXILIARY LANES FOR LEFT TURN BAY/NO PASSING BLISTER

NO SCALE

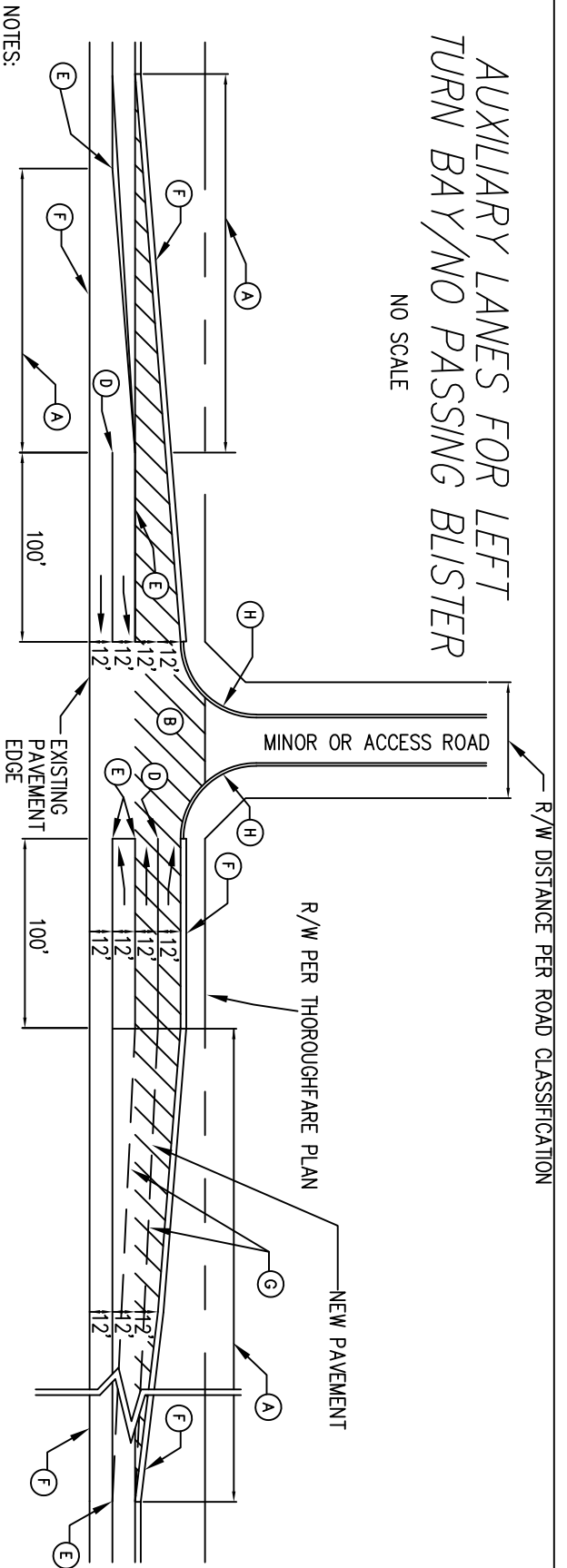

NOTES:

1. CONSTRUCTION PLANS SHALL INCLUDE CENTERLINE PROFILE OF EXISTING ROAD BEING INTERSECTED BY THE ENTRANCE. THE PROFILE SHALL EXTEND A MINIMUM OF 500' EACH DIRECTION FROM ENTRANCE CENTERLINE. LOCATION OF MINOR ROAD SHALL BE SUCH THAT SSD ON MAJOR ROAD IS PROVIDED.
2. THE CITY ENGINEER, AT ITS DISCRETION, MAY REQUIRE THE CONNECTION OF AUXILIARY LANES BETWEEN DEVELOPMENTS, EVEN IF WORK EXCEEDS THAT REQUIRED ON THIS DETAIL
3. AUXILIARY LANES (ACCELERATION TAPER, DECELERATION TAPER, DECELERATION LANE AND PASSING BLISTER) ARE REQUIRED AT ALL SUBDIVISION ENTRANCES WHERE R/W EXISTS PURSUANT TO CITY OF CARMEL ORDINANCES.
4. MILL THE FULL WIDTH OF THE EXISTING PAVEMENT 1.5" AND RESURFACE WITH 1.5" HMA SURFACE, 9.5 mm. WORK SHALL EXTEND ACROSS ENTIRE FRONTAGE OF PROPERTY OR TO LIMITS OF AUXILIARY LANES, WHICHEVER IS GREATER.
5. IF THESE DIMENSIONS CONFLICT WITH THE DIMENSIONS PRESENTED IN CITY OF CARMEL ORDINANCES, THE REQUIREMENTS RESULTING IN LARGER DIMENSIONS SHALL APPLY.

- (A) DIMENSIONS SHALL BE IN ACCORDANCE WITH MOST RECENT VERSION OF MUTCD
- (B) PAVEMENT SECTION PER ROAD CLASSIFICATION BACK TO RIGHT OF WAY.
- (D) 4" THERMOPLASTIC SOLID WHITE
- (E) 4" THERMOPLASTIC DOUBLE YELLOW FOR ENTIRE RESURFACING AREA
- (F) 3", COMPACTED AGGREGATE #73 GRAVEL SHOULDER, 6" DEPTH. SSD MEETING CITY OF CARMEL DETAIL 10-12 SHALL BE INSTALLED UNDER SHOULDER AND CONNECTED TO ON-SITE STORM SEWER SYSTEM.
- (G) 4" THERMOPLASTIC, DOTTED, WHITE, 2' STRIPE - 2' GAP
- (H) 40' MINIMUM RADIUS SHALL BE PROVIDED REGARDLESS OF MAJOR/MINOR ROAD CLASSIFICATION.

STANDARD
DRAWING
10-36

CITY OF CARMEL STANDARDS
AUXILIARY LANES FOR LEFT TURN BAY

RAILING NOTES

- 1) HANDRAIL MATERIALS AND WORK SPECIFICATIONS SHALL BE IN ACCORDANCE WITH THE MOST CURRENT VERSION OF INDIANA DEPARTMENT OF TRANSPORTATION STANDARD SPECIFICATIONS AND SUPPLEMENTAL SPECIFICATIONS UNLESS OTHERWISE NOTED.
- 2) ALL PIPE MATERIAL SHALL BE SCHEDULE 40, ASTM A53, GR. B.
- 3) HANDRAILS SHALL BE GALVANIZED STEEL WITH PRIMER AND BLACK POWDER COATING MATERIALS PER TECHNICAL SPECIFICATIONS.
- 4) FOOTING AND POST EMBEDMENT TO BE DESIGNED BY THE DESIGNER. THE USE OF THE BASE PLATE/DROP-IN ANCHOR OPTION IS ONLY PERMITTED WHEN EMBEDDING THE POST IS NOT FEASIBLE. THE USE OF THE BASE PLATE/DROP-IN ANCHOR OPTION MAY BE APPROVED BY THE ENGINEER.

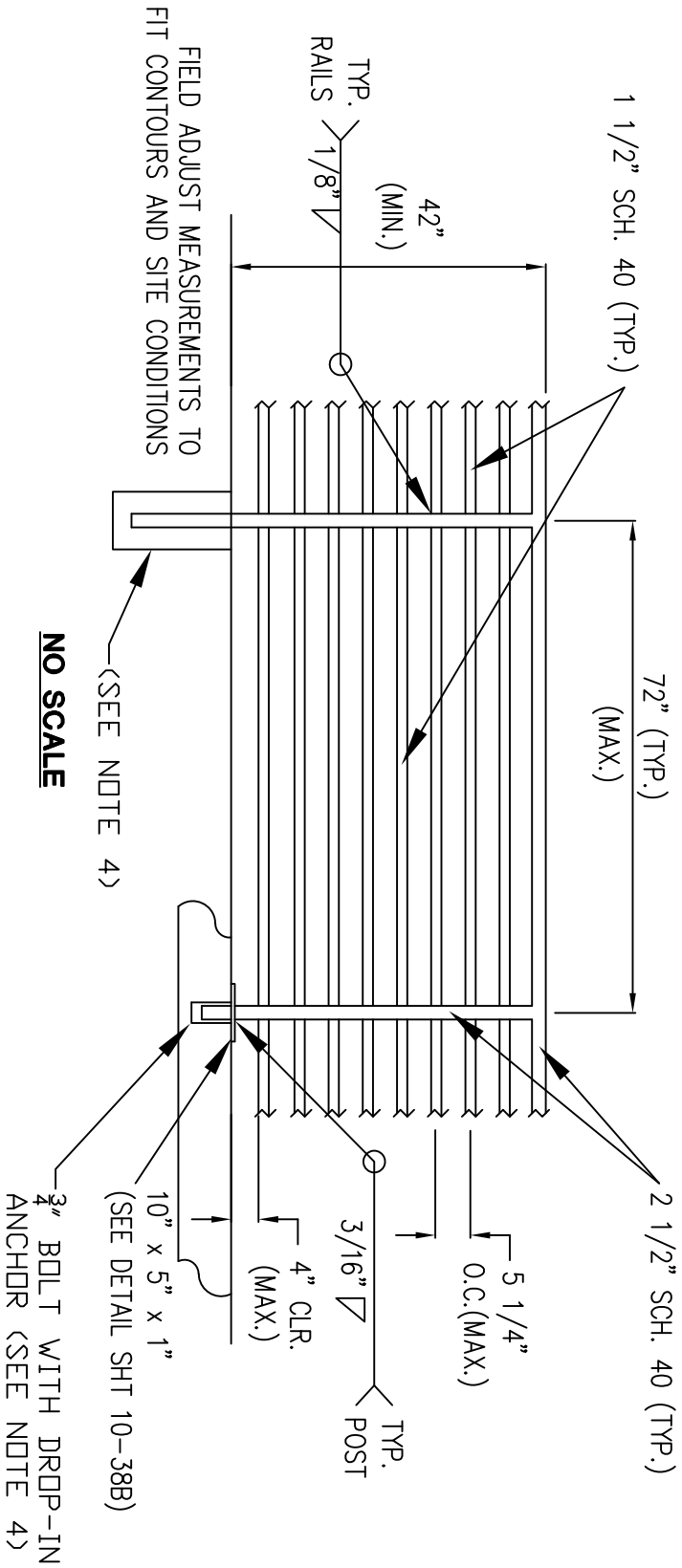

STANDARD
DRAWING
10-37A

CITY OF CARMEL STANDARDS

HANDRAIL

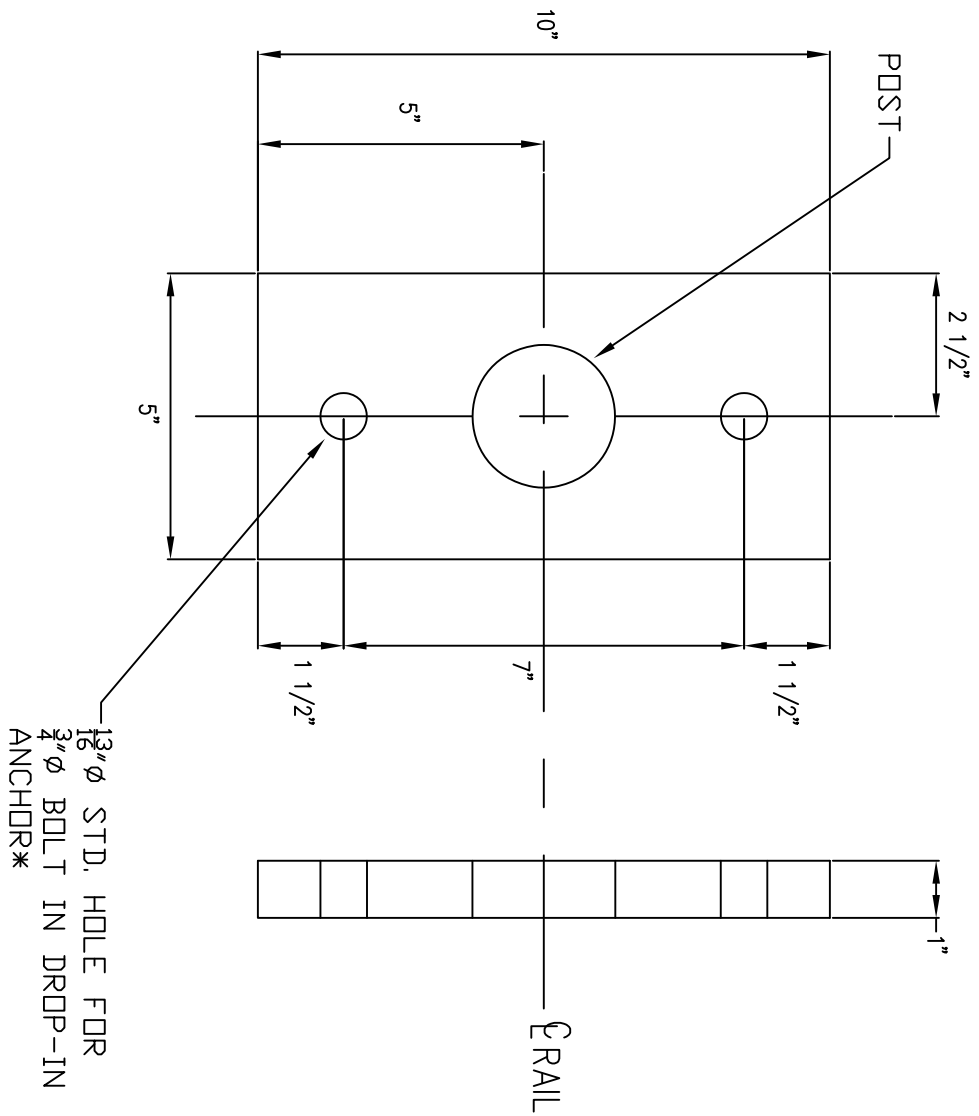

NO SCALE

* DROP-IN ANCHOR SHALL HAVE A
MINIMUM ALLOWABLE TENSILE
CAPACITY OF 3,000 LBS.

STANDARD DRAWING 10-37B	<i>CITY OF CARMEL STANDARDS</i>	
	HANDRAIL BASE PLATE DETAIL	

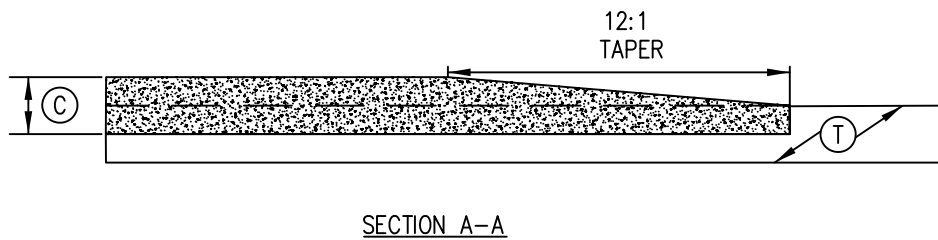
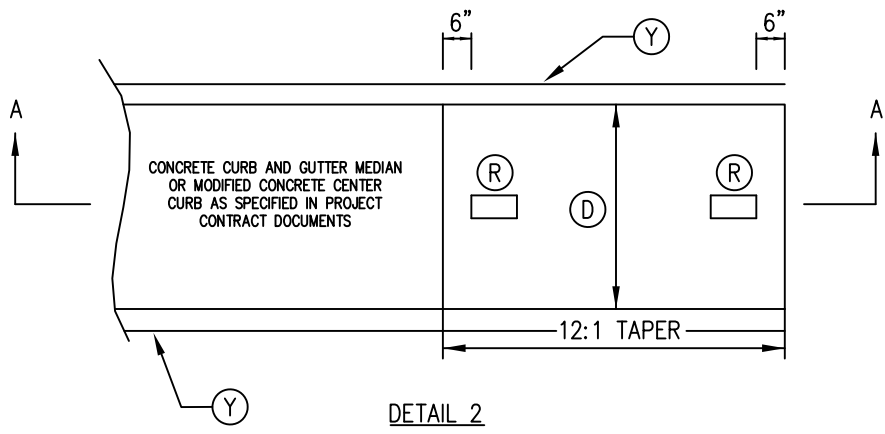
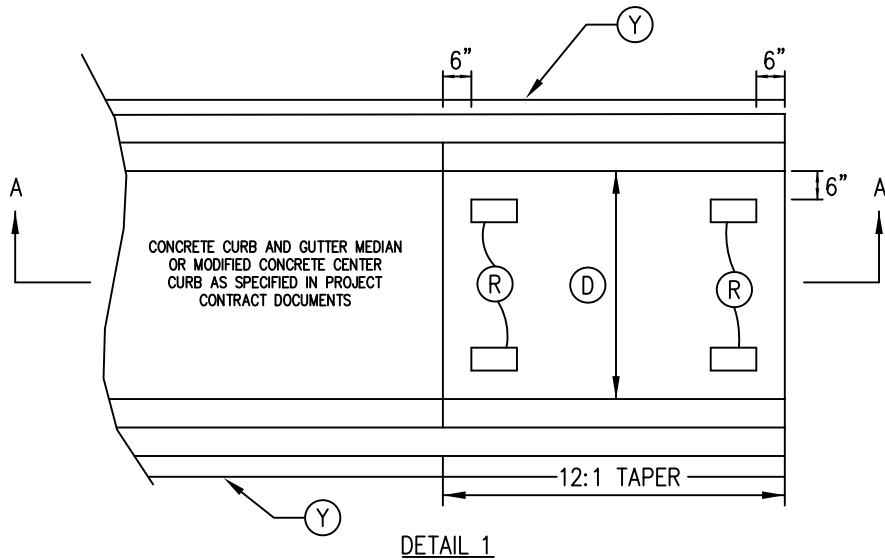

NOTES:

- (D) WIDTH GREATER THAN 3' REQUIRES 4 RPMS PER DETAIL 1 OR 3' WIDTH OR LESS REQUIRES 2 RPMS PER DETAIL 2 CENTERED ON WIDTH OF MEDIAN
- (R) RPM (YELLOW)
- (Y) LINE, THERMOPLASTIC, YELLOW, 4IN.

LEGEND

- (C) CURB DEPTH AS SPECIFIED
- (T) TYPICAL PAVEMENT SECTION

STANDARD
DRAWING
10-38

CITY OF CARMEL STANDARDS

CONCRETE CURB END TREATMENT DELINEATION

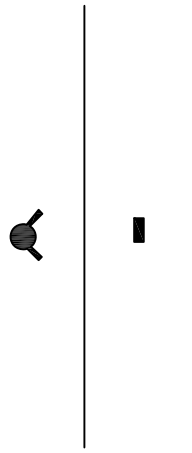

(A)

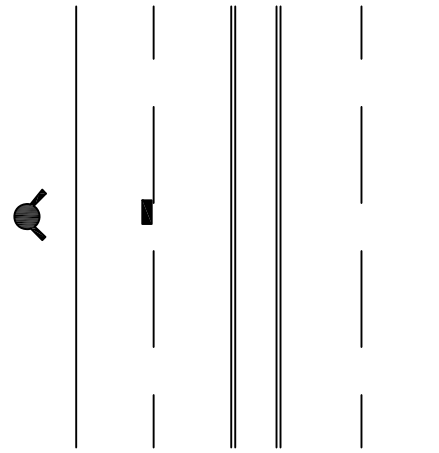

(B)

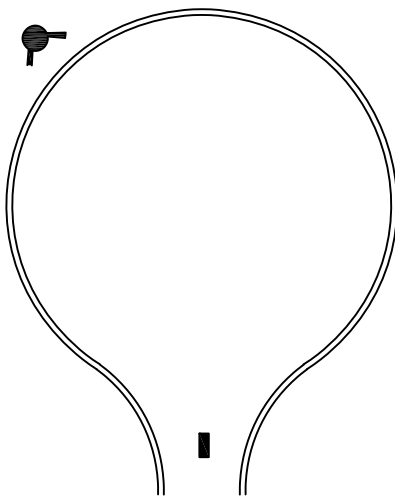

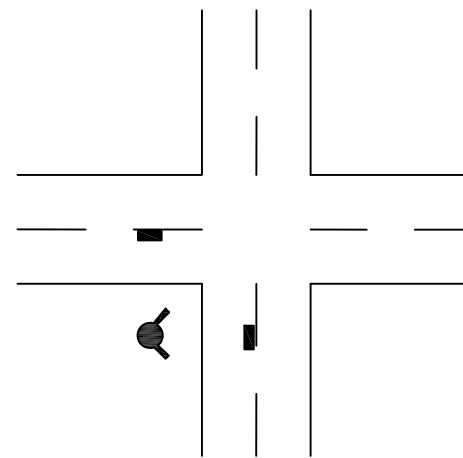

(C)



(D)

LEGEND

-  RPM TYPE 2 (BLUE) PER INDOT STANDARD DWG E 808-MKRM-11
-  FIRE HYDRANT

NOTES:

- (A) FOR PAVED UNDIVIDED ROAD SURFACES PLACEMENT SHALL BE IN THE CENTER OF THE STREET.
- (B) FOR DIVIDED MULTI-LANE ROAD SURFACES PLACEMENT SHALL BE IN CENTER DIVIDER LANE CLOSEST TO HYDRANT LOCATION.
- (C) FOR CUL-DE-SAC APPLICATIONS PLACEMENT SHALL BE AT THE BEGINNING OF THE CUL-DE-SAC CIRCLE IN THE CENTER OF THE STREET.
- (D) FOR INTERSECTION APPLICATIONS PLACEMENT SHALL BE CENTER SURFACE DIVIDER CLOSEST TO HYDRANT LOCATION IN EITHER TRAVEL DIRECTION.

STANDARD
DRAWING
10-39

CITY OF CARMEL STANDARDS

FIRE HYDRANT MARKER PLACEMENT

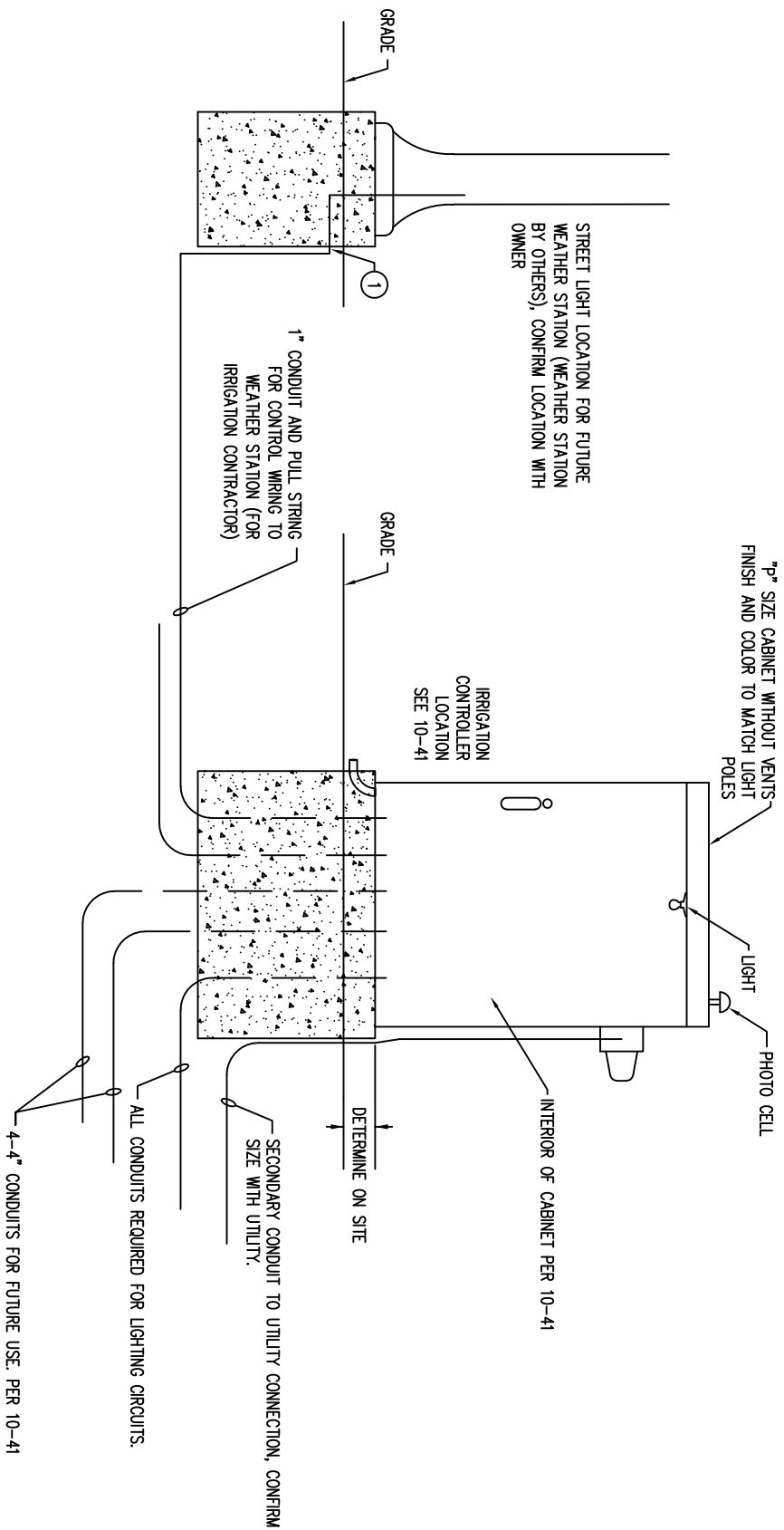

1 SERVICE AND CONTROL CABINET DETAIL
 NOT TO SCALE

- NOTES:
- ① NOTCH EXISTING CONCRETE BASE AND INSTALL CONDUIT, PATCH WITH GROUT (ONLY REQUIRED WHERE POLE FOUNDATION ALREADY EXISTS).
 - ② ALL BENDS ARE TO BE SWEEPING ELBOWS.
 - ③ ALL CONDUIT SHALL HAVE LOCATE WIRE.

REVISED 4-5-17

STANDARD
 DRAWING
 10-40

CITY OF CARMEL STANDARDS
 SERVICE AND CONTROL CABINET DETAIL

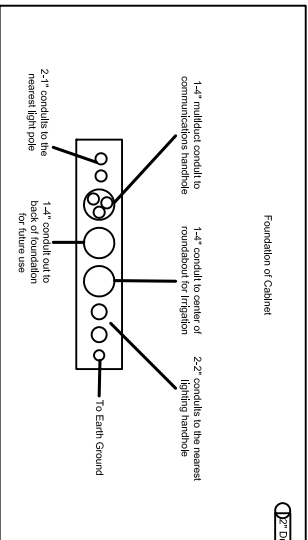
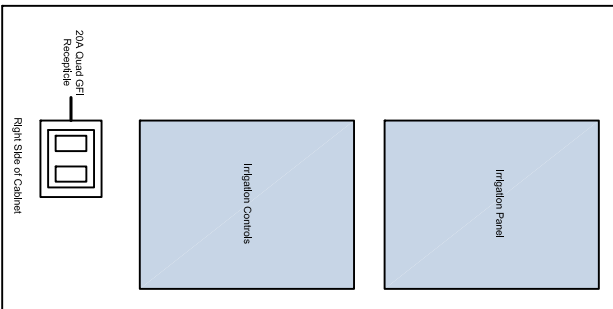
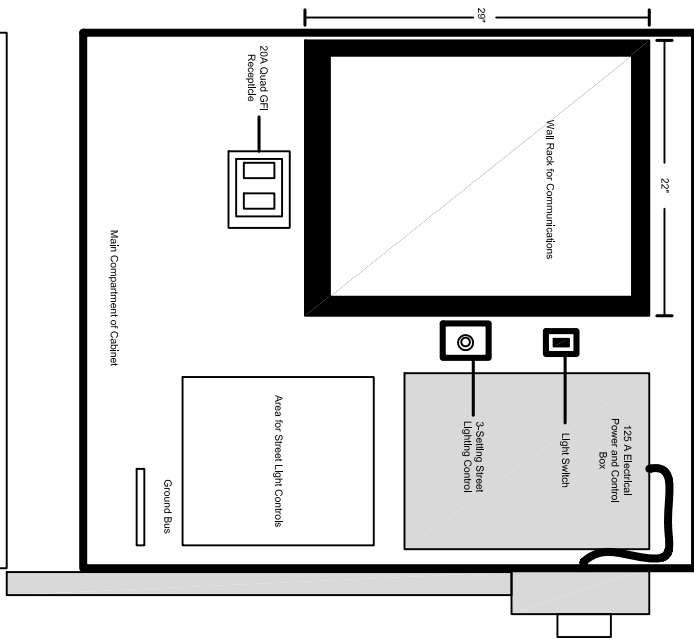
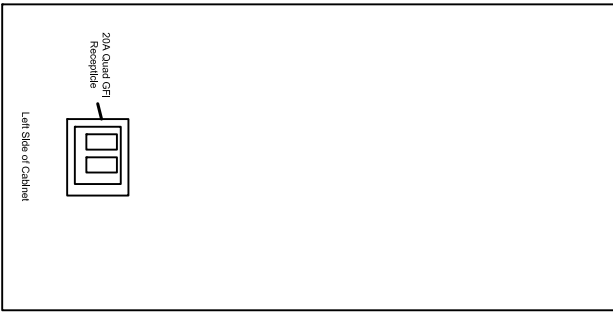
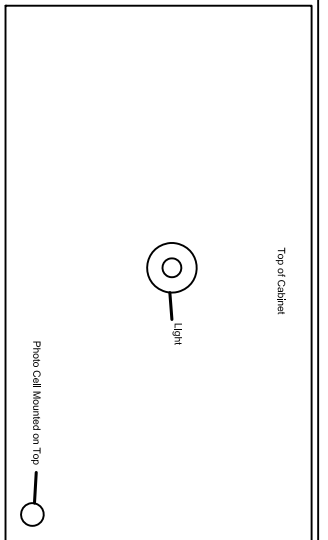

Service and Control Cabinet Detail

Not to Scale

REVISED 4-19-17

STANDARD DRAWING
10-41

CITY OF CARMEL STANDARDS
SERVICE AND CONTROL CABINET INTERIOR DETAIL

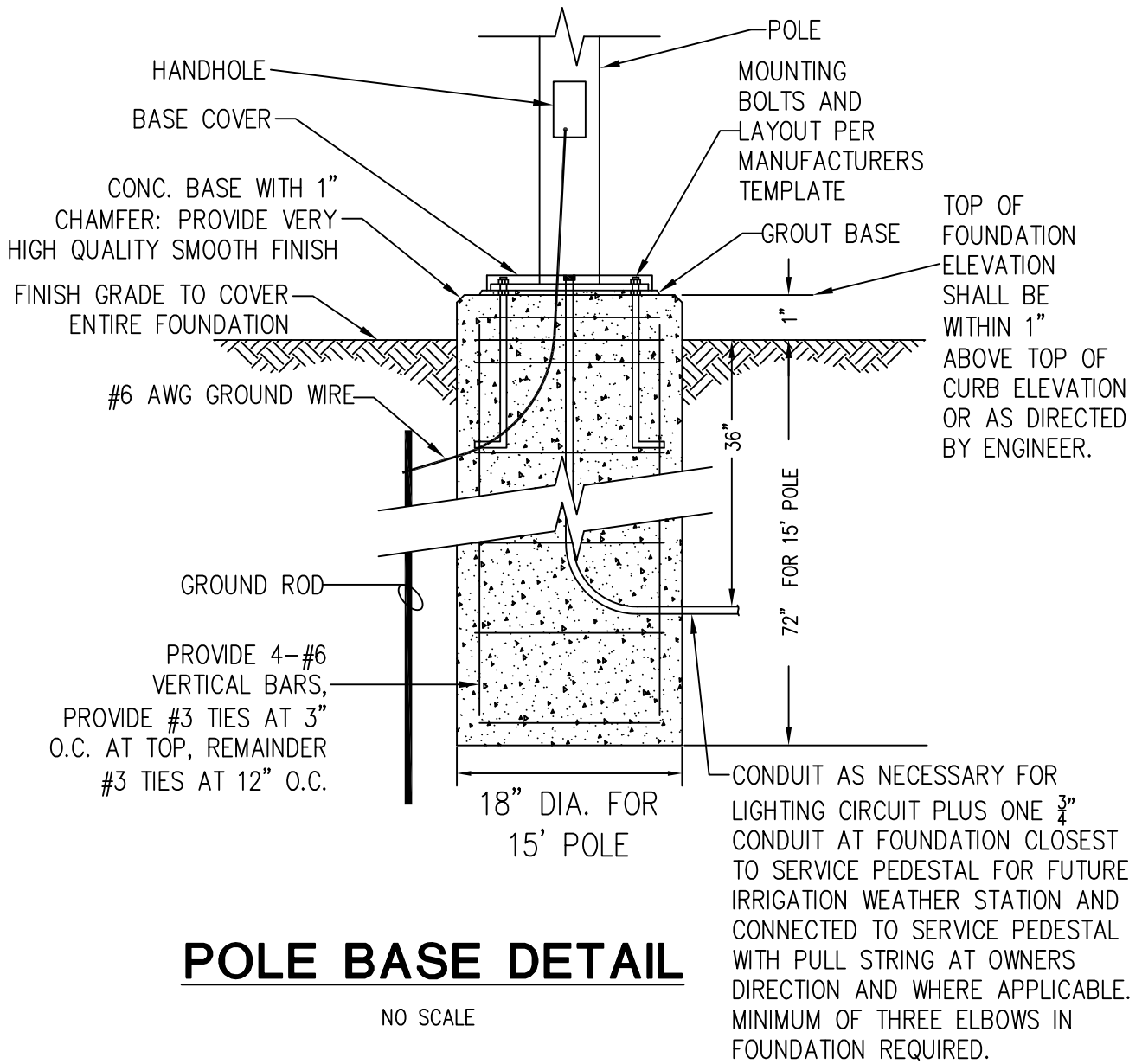

POLE BASE DETAIL

NO SCALE

REVISED 3-23-17

STANDARD
DRAWING
10-42A

CITY OF CARMEL STANDARDS

15' LIGHT POLE FOUNDATION DETAIL

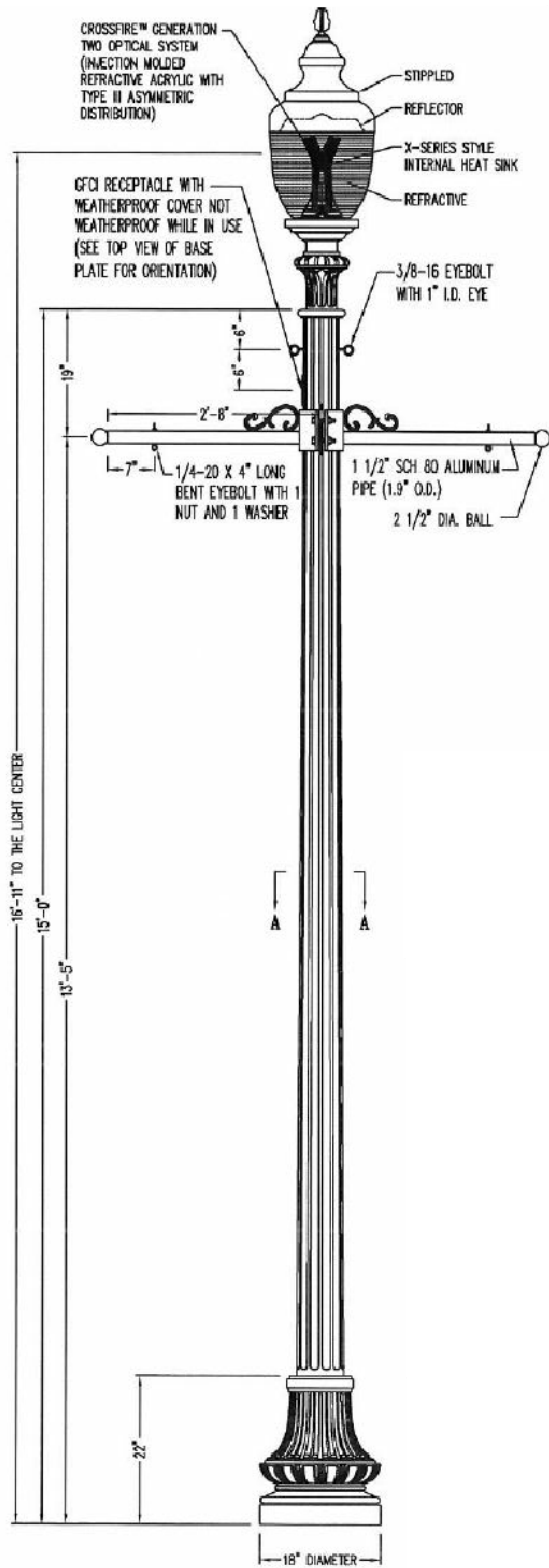

LUMINAIRE SPECIFICATIONS

STYLE:	WASHINGTON WITH THE X-SERIES LED MODULE, T18 REFRACTIVE GLOBE AND FINIAL
HEIGHT:	44 3/8"
WIDTH:	15 7/8"
MATERIAL:	CAST ALUMINUM ALLOY AMSI 350 PER A.S.T.M. B28-85
FINISH:	POWDER COAT - RIVER TEXTURE BLACK
LAMPING:	70 WATT LED
VOLTAGE:	ELECTRONIC WIRE AT 120-277 VOLTS
COLOR TEMP:	4000K (MEDIUM WHITE)
OPTICS:	TYPE II CROSSFIRE REFRACTIVE OPTICS (ASYMMETRIC DISTRIBUTION)
GLOBE:	TYPE II REFRACTIVE POLYCARBONATE
CATALOG NO.:	ALMWSH-LED70/EVX/A18-40-OR3-PFB3-FPP-CU

LAMP POST SPECIFICATIONS

STYLE:	WASHINGTON STEEL
HEIGHT:	15'-0"
LIGHT CENTER:	15'-11"
BASE:	18" DIAMETER
MATERIAL:	11 GAUGE MIN., 12 FLAT FLUTE, STEEL MONOTUBE CONSTRUCTION
SHAFT:	1 PIECE, (SLIP OVER) HEAVY WALL CAST IRON PER A.S.T.M. A 48-83 CLASS 30
BASE:	PRIME PAINT THEN FINISH PAINT SHERWIN WILLIAMS ACRIDIPOL CLASSIC BLACK
FINISH:	ACRIDIPOL CLASSIC BLACK
ACCESS DOOR:	LOCATED IN BASE TO COINCIDE WITH HAND HOLE IN STEEL SHAFT SECURED WITH FLAT HEAD HEX SOCKET SECURITY MACHINE SCREWS
GROUND STUD PROVISIONS:	1/4"-20 SQUARE NUT WELDED TO INSIDE WALL OF POLE OPPOSITE HAND HOLE FOR GROUND STUD (STUD PROVIDED BY OTHERS)
ANCHOR BOLTS:	(4) 3/4" X 24" ± 3" HOOK (FULLY GALVANIZED WITH 2 GALVANIZED NUT AND 2 GALVANIZED WASHER PER BOLT) - SEE QUANTITY WHEN REQ'D
BOLT PROJECTION:	5" REQUIRED
TENON:	3 1/2" DIA. X 3" HIGH (ABOVE DONUT) TO ACCEPT LUMINAIRE
CATALOG NO.:	SS12F-611-07.50-15.00-1N3.50/3.00-(2)FB-(2)EB-6FIN-08
SHAFT:	18WSH-18-08
BASE:	

REVISED 3-22-17

STANDARD
DRAWING
10-42B

CITY OF CARMEL STANDARDS

15' LIGHT POLE DETAIL

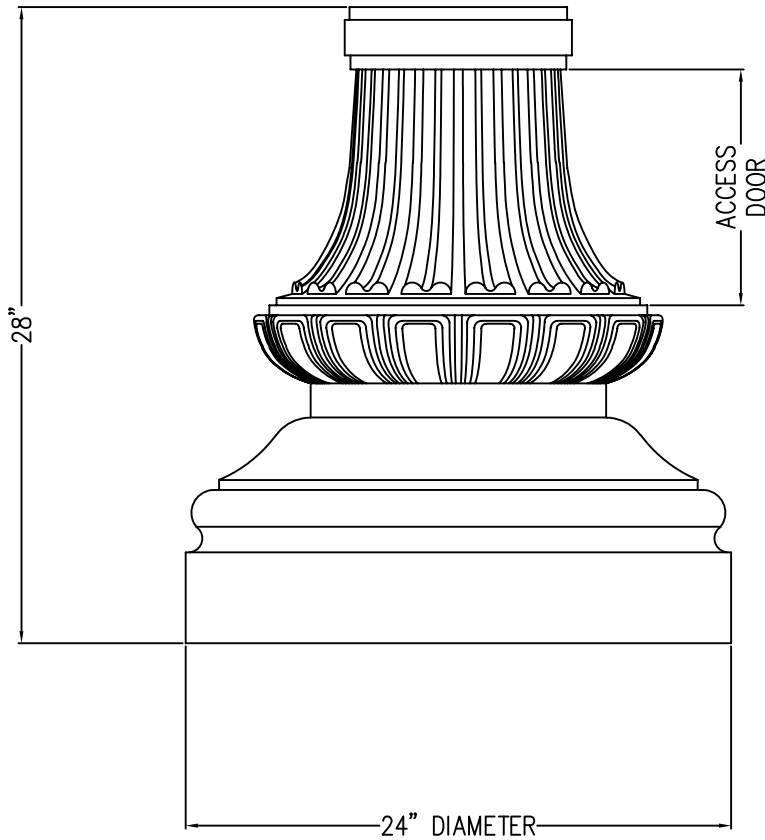

CAST BASE SPECIFICATIONS

STYLE: WASHINGTON
 HEIGHT: 28"
 BASE: 24" DIAMETER □SLIP BASE □WRAP BASE
 MATERIAL: □CAST ALUMINUM ALLOY SR319 PER A.S.T.M. B26-95
 □CAST IRON PER A.S.T.M. A 48-83 CLASS 30 - CLASSIC BLACK
 □CAST DUCTILE IRON PER A536-84 GRADE 65-45-12
 FINISH: PRIME PAINT THEN FINISH SHERWIN WILLIAMS ACRYLON - ACRYLON CLASSIC BLACK
 ACCESS DOOR: LOCATED IN BASE SECURED WITH TAMPER PROOF HEX SOCKET SECURITY MACHINE SCREWS

DECO WRAP BASE

NO SCALE

REVISED 3-22-17

STANDARD
DRAWING
10-42C

CITY OF CARMEL STANDARDS

DECO WRAP BASE

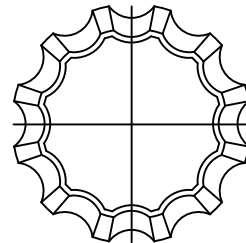
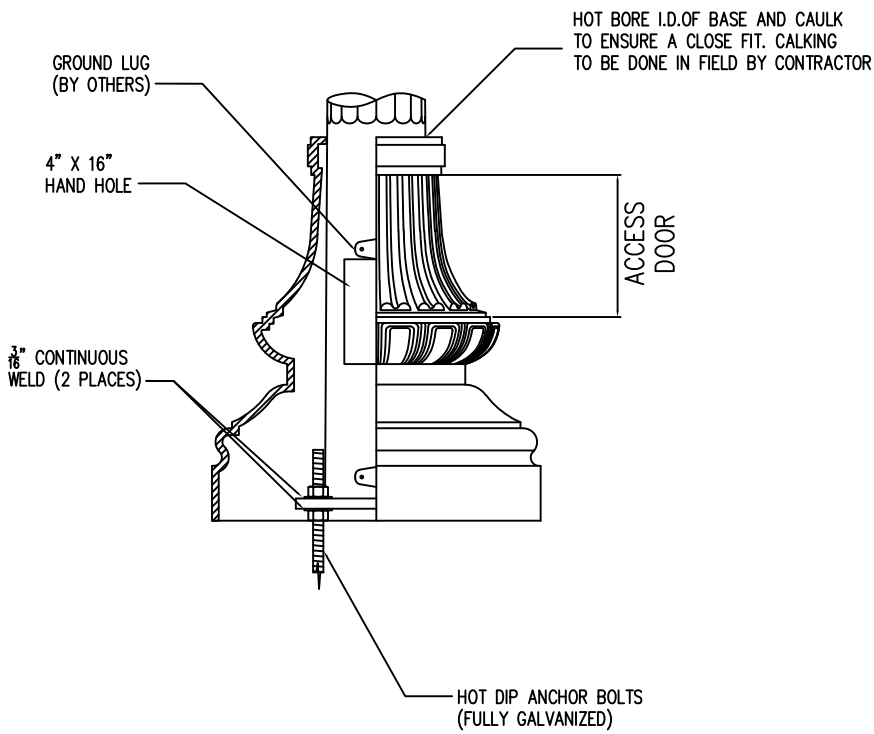
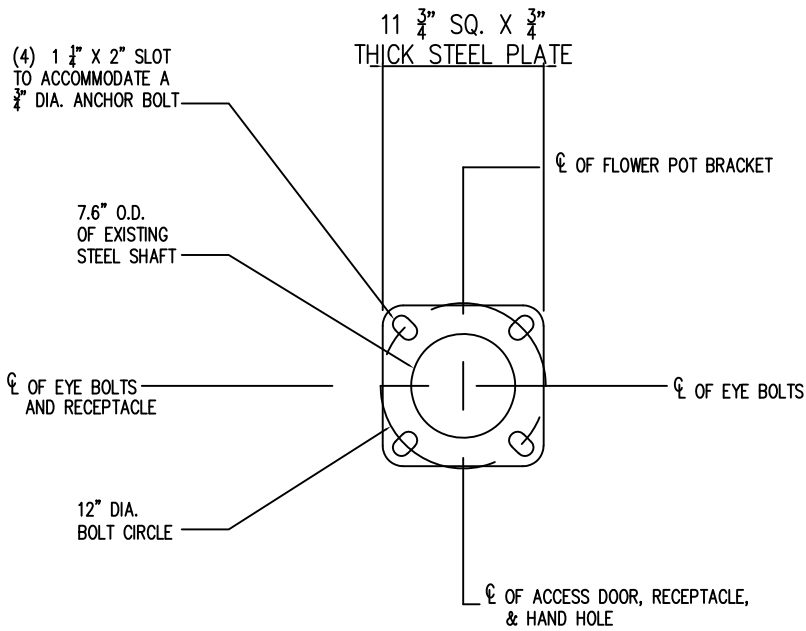

SECTION A-A
 12 FLAT FLUTE
 11 GAUGE STEEL
 N.T.S.

REVISED 4-5-17

STANDARD
 DRAWING
 10-42D

CITY OF CARMEL STANDARDS
 MISCELLANEOUS 15' LIGHT POLE DETAILS

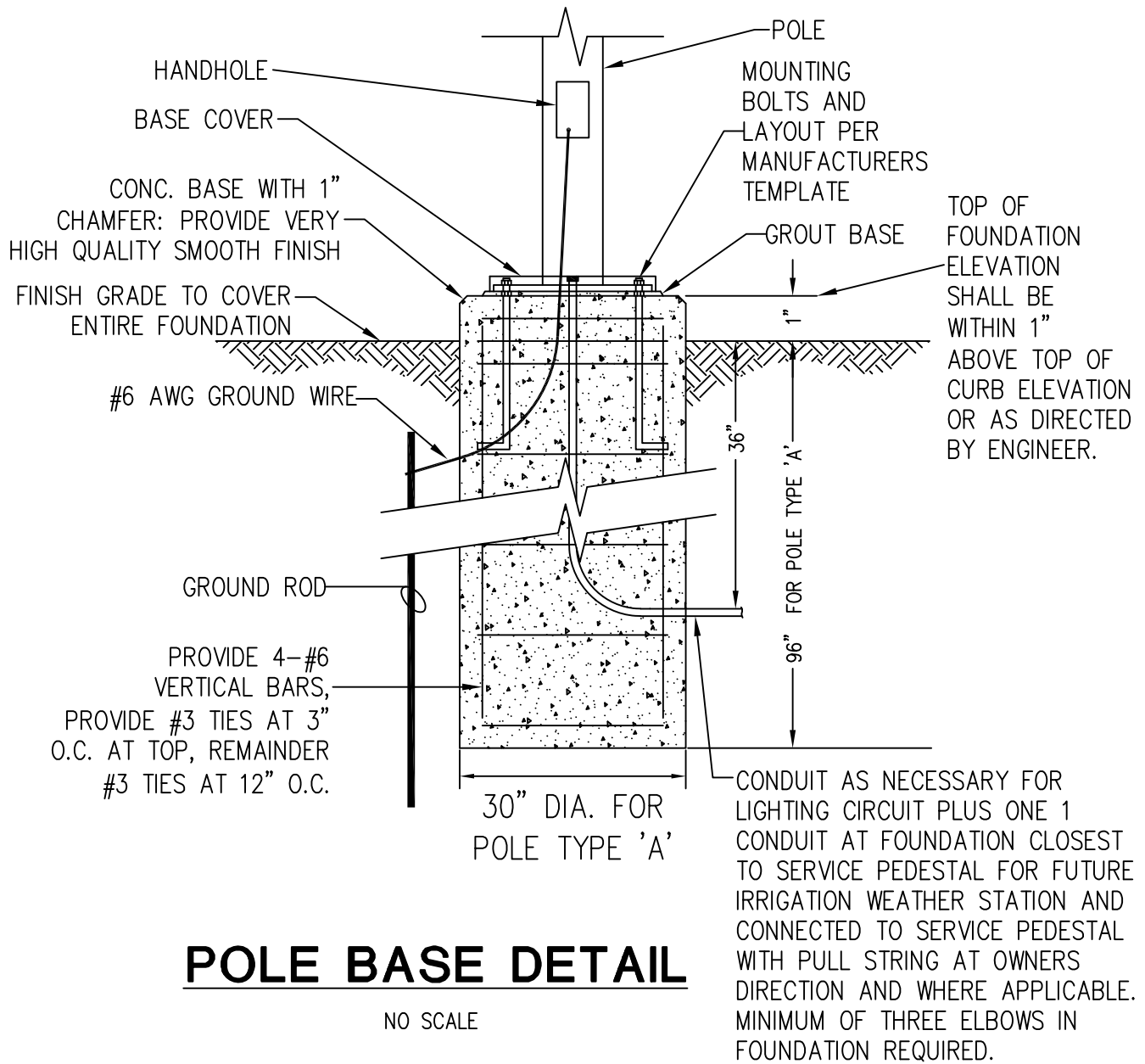

POLE BASE DETAIL

NO SCALE

REVISED 3-23-17

STANDARD
DRAWING
10-43A

CITY OF CARMEL STANDARDS

30' LIGHT POLE FOUNDATION DETAIL

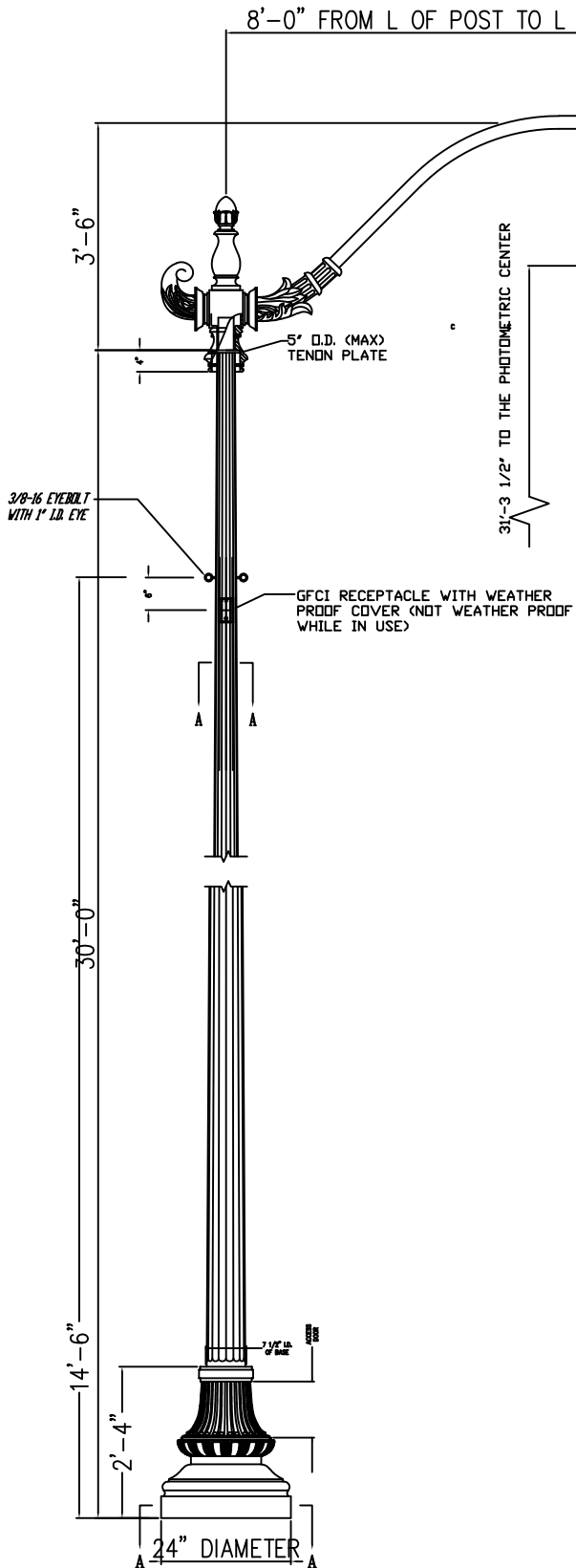

LUMINAIRE SPECIFICATIONS

Style: Columbia
 HEIGHT: 22 1/2"
 WIDTH: 17 3/4"
 MATERIAL: CAST ALUMINUM ALLOY A.N.S.I. 356, PER A.S.T.M. B26-95
 LENS: FLAT CLEAR GLASS
 FINISH: PRIME PAINT THEN FINISH SHERWIN WILLIAMS ACRYLON CLASSIC BLACK
 LAMPING: 152 WATT
 COLOR TEMPERATURE: 6000K
 VOLTAGE: 120 - 277 VOLT
 DISTRIBUTION: TYPE II (ASYMMETRIC) DISTRIBUTION

CROSS ARM SPECIFICATIONS

Style: Northampton
 HEIGHT: 3'-6"
 WIDTH: 8'-0" FROM C OF POST TO C OF LUMINAIRE
 MATERIAL: 2" SCH. 40 STEEL PIPE WITH CAST DUCTILE IRON ORNAMENTATION
 FINISH: PRIME PAINT THEN FINISH SHERWIN WILLIAMS ACRYLON CLASSIC BLACK
 TENDON: 2" NPT PIPE NIPPLE

LAMP POST SPECIFICATIONS

Style: Washington Steel
 HEIGHT: 30'-0" EXISTING
 LIGHT CENTER: 31'-3 3/4"
 BASE: 24" DIAMETER WRAP BASE, HEIGHT: 28"
 MATERIAL: CAST IRON SEE NEXT SHEET FOR DETAIL
 SHAFT: EXISTING 7.6" O.D. AT BOTTOM OF SHAFT WITH .14"/FT TAPER
 BASE: 2 PIECE (WRAP AROUND) CAST IRON PER A.S.T.M. A48-83 CLASS 30
 FINISH: PRIME PAINT THEN FINISH SHERWIN WILLIAMS ACRYLON CLASSIC BLACK
 ACCESS DOOR: LOCATED IN BASE, TO COINCIDE WITH HAND HOLE IN STEEL SHAFT, SECURED WITH TAMPER PROOF HEX SOCKET SECURITY MACHINE SCREWS
 TENDON: 2 7/8" DIA. X 6' HIGH (TO ACCEPT CROSS ARM)

REVISED 3-22-17

STANDARD
 DRAWING
 10-43B

CITY OF CARMEL STANDARDS

30' LIGHT POLE DETAIL

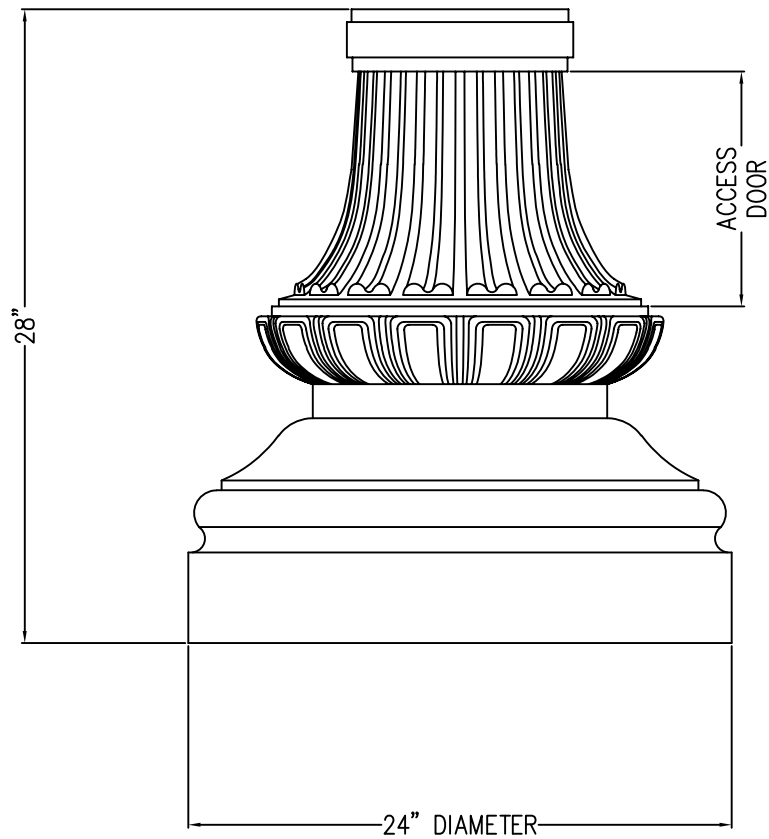

CAST BASE SPECIFICATIONS

STYLE: WASHINGTON
 HEIGHT: 28"
 BASE: 24" DIAMETER □SLIP BASE □WRAP BASE
 MATERIAL: □CAST ALUMINUM ALLOY SR319 PER A.S.T.M. B26-95
 □CAST IRON PER A.S.T.M. A 48-83 CLASS 30 - CLASSIC BLACK
 □CAST DUCTILE IRON PER A536-84 GRADE 65-45-12
 FINISH: PRIME PAINT THEN FINISH SHERWIN WILLIAMS ACROLDON - ACROLDON CLASSIC BLACK
 ACCESS DOOR: LOCATED IN BASE SECURED WITH TAMPER PROOF HEX SOCKET SECURITY MACHINE SCREWS

DESCRIPTION

24" WRAP BASE (FOR EXISTING 7.6"
 O.D. BOTTOM 30'-0" STEEL SHAFT)
 AND THE SINGLE CROSS ARM WITH
 THE FULL CUT-OFF LED LUMINAIRE

DECO WRAP BASE

NO SCALE

REVISED 3-22-17

STANDARD
 DRAWING
 10-43C

CITY OF CARMEL STANDARDS

DECO WRAP BASE

7.6" O.D.
OF EXISTING
STEEL SHAFT

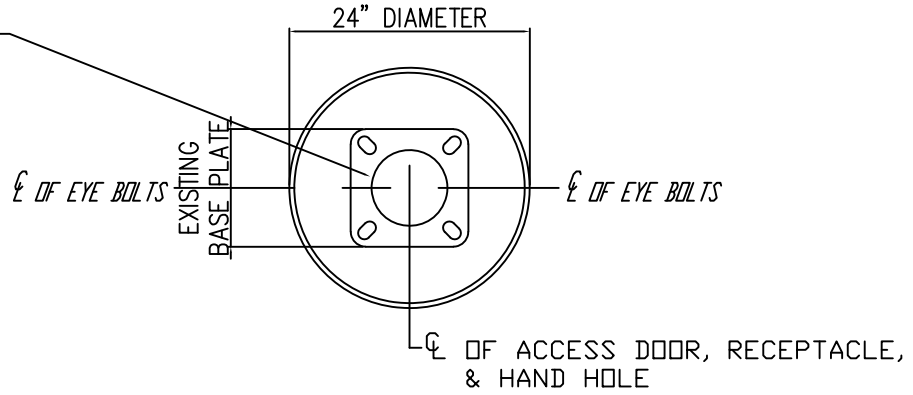

SECTION A-A
N.T.S.

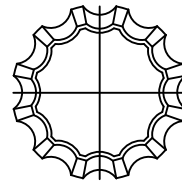

EXISTING 7 GAUGE STEEL
SHAFT
12 FLAT FLUTE

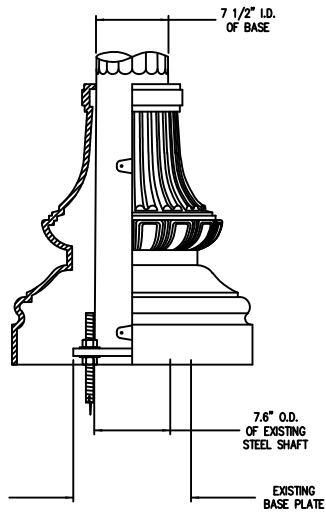

REVISED 4-5-17

STANDARD
DRAWING
10-43D

CITY OF CARMEL STANDARDS

MISCELLANEOUS 30' LIGHT POLE DETAILS

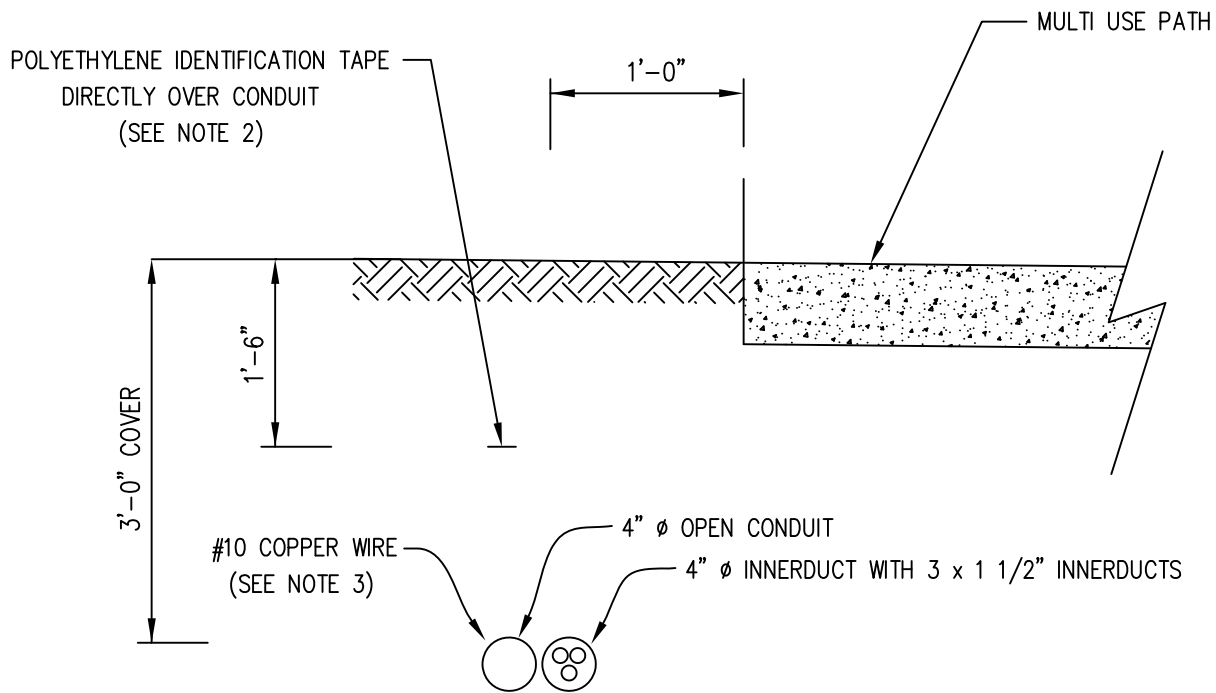

CONDUIT/INNERDUCT DETAIL

NO SCALE

NOTES:

- 1) 4" ϕ CONDUIT SHALL BE PVC SCHEDULE 40. THE INNERDUCTS SHALL BE SPECIFICALLY DELINEATED WITH 3 CONTRASTING COLORS.
- 2) THE POLYETHYLENE IDENTIFICATION TAPE SHALL BE METALLIC AND HAVE A MINIMUM THICKNESS OF 4 MILS. THE TAPE SHALL READ "CAUTION BURIED FIBER OPTIC". TAPE SHALL BE PLACED DIRECTLY OVER PIPE AND 18" BELOW FINAL GRADE.
- 3) 10 GAUGE INSULATED SOLID COPPER LOCATING WIRE SHALL RUN THE LENGTH OF THE CONDUIT AND SHALL BE ATTACHED DIRECTLY TO THE OUTSIDE OF THE OPEN CONDUIT EVERY 10 FEET. THE LOCATING WIRE SHALL EXTEND INTO THE HANDHOLES WITH A MINIMUM OF 5' OF COILED WIRE IN THE HANDHOLE FOR EACH DIRECTION AND SPLICED WITHIN THE HANDHOLE FOR LOCATING PURPOSES.
- 4) HANDHOLES SHALL BE PLACED AT LOCATIONS DESIGNATED BY THE CITY ENGINEER, BUT NO GREATER THAN 400 FEET APART.
- 5) DEVELOPER SHALL SUBMIT SHOP DRAWINGS OF INNERDUCT AND HANDHOLES FOR REVIEW AND APPROVAL.
- 6) #8 STONE SHALL BE UTILIZED AS BACKFILL FOR ANY CONDUIT PLACED UNDER PAVEMENT CROSSINGS.

REVISED 3-23-17

STANDARD
DRAWING
10-44

CITY OF CARMEL STANDARDS

CONDUIT/INNERDUCT DETAIL CITY OF CARMEL

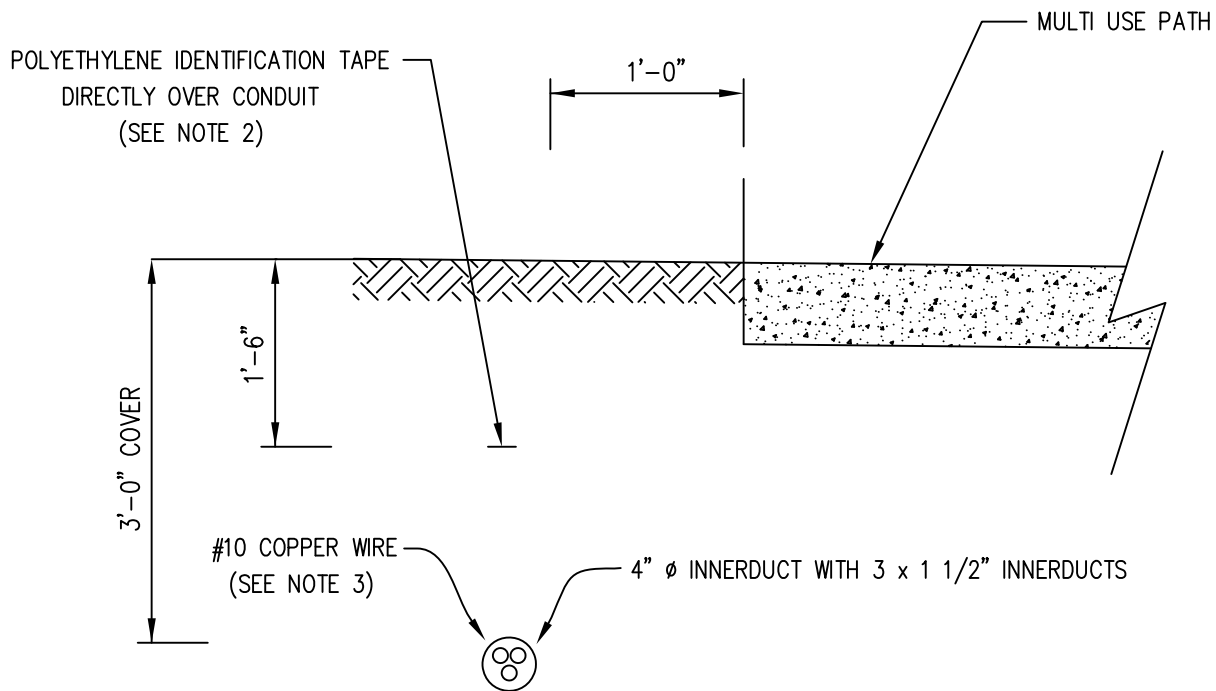

CONDUIT/INNERDUCT DETAIL—CARMEL COMMUNICATIONS

NO SCALE

NOTES:

- 1) 4" ϕ CONDUIT SHALL BE PVC SCHEDULE 40. THE INNERDUCTS SHALL BE SPECIFICALLY DELINEATED WITH 3 CONTRASTING COLORS.
- 2) THE POLYETHYLENE IDENTIFICATION TAPE SHALL BE METALLIC AND HAVE A MINIMUM THICKNESS OF 4 MILS. THE TAPE SHALL READ "CAUTION BURIED FIBER OPTIC". TAPE SHALL BE PLACED DIRECTLY OVER PIPE AND 18" BELOW FINAL GRADE.
- 3) 10 GAUGE INSULATED SOLID COPPER LOCATING WIRE SHALL RUN THE LENGTH OF THE CONDUIT AND SHALL BE ATTACHED DIRECTLY TO THE OUTSIDE OF THE OPEN CONDUIT EVERY 10 FEET. THE LOCATING WIRE SHALL EXTEND INTO THE HANDHOLES WITH A MINIMUM OF 5' OF COILED WIRE IN THE HANDHOLE FOR EACH DIRECTION AND SPLICED WITHIN THE HANDHOLE FOR LOCATING PURPOSES.
- 4) HANDHOLES SHALL BE PLACED AT LOCATIONS DESIGNATED BY THE CITY ENGINEER, BUT NO GREATER THAN 400 FEET APART.
- 5) DEVELOPER SHALL SUBMIT SHOP DRAWINGS OF INNERDUCT AND HANDHOLES FOR REVIEW AND APPROVAL.
- 6) #8 STONE SHALL BE UTILIZED AS BACKFILL FOR ANY CONDUIT PLACED UNDER PAVEMENT CROSSINGS.

REVISED 3-23-17

STANDARD
DRAWING
10-45

CITY OF CARMEL STANDARDS

CONDUIT/INNERDUCT DETAIL—CARMEL COMMUNICATIONS